

ONPACHONGUN TAKO NAN KALI  
ASNAN MANOKATAN TAKO ASNAN LETRA

- 2 -

(Let's Compare Words by Changing a Letter)

An Easy Reader in E. Bontok

Prepared by

Takashi & Aiko Fukuda and Dave & Joan Ohlson

Illustrated by

Baldwin Ngolab

Summer Institute of Linguistics, Inc.

Translators

Publishers

1978

Published  
in cooperation with  
Bureau of Elementary Education  
and  
Institute of National Language  
of the  
Department of Education and Culture  
Manila, Philippines

Additional copies of this publication  
may be obtained from:

FilLit  
Box 2270  
Manila 2801

FilLit  
SIL, Bagabag Airport  
Bagabag, Nueva Vizcaya 1505

55.9-578-5.4C

54.30P-786036B015

Printed in the Philippines

## FOREWORD

Some of the glory of the Philippines lies in the beautiful variety of people and languages within its coasts. It is to the great credit of the national leadership over the years that no attempt has been made to destroy this national heritage. The goal has been instead to preserve its integrity and dignity while building on this strong foundation a lasting superstructure of national language and culture.

The present book is one of many designed for this purpose. It recognizes the pedagogical importance of dividing literacy and second language learning into two steps -- literacy being the first. When a student has learned to read the language he understands best, the resulting satisfaction in his accomplishment gives the drive and confidence he needs to learn the national language. His ability to read, furthermore, is the indispensable tool for the study this program will require.

The Department of Education and Culture of the Philippines is proud to present this latest volume in a nationwide series designed to teach the national language through literacy in the vernaculars. It will strengthen both the parts of the nation and the whole.

JUAN L. MANUEL  
Secretary

To the teacher:

The purpose of this book is to help beginning students understand the relationship of samenesses and differences in sounds to what-is-written. By comparing the pictured words, the student will find;

1. When the sounds are the same, the letters are also the same.
2. When the sound changes a little, the letters also change a little.

Say to the student:

Look at the pictures on the left. Look at the writing beside the pictures. The pictures show you what the words say. Read the words. Name the pictures again, think about the difference of the sounds. Read the words again, see the difference in the letters.

Look at the pictures on the next page. Beside each picture are two words. Read the words, then point to the one that names the picture.

Asnan mistara ya mistaro:

Nan na-oy ay liblo at fomachang asnan mangelapowan nan oswela ay mangawat hennan onpachongan ya achicha onpachongan asnan kadngorana asnan ma-isosorat. Asnan ma-ipachongan hennan eklato ya nan kali, nan oswela ma-anapana:

1. Mo on-iso nan kadngorana on-iso os nan letra.
2. Mo na kadngorana at masokatan at nan letra masokatan os.

Kanam asnan oswela:

Ela-om nan eklato as kanikid. Ela-om nan ma-isosorat asnan sag-un nan eklato. Nan eklato epa-ila na nan laychun ay kanan nan kali. Fiasa-om nan kali kasim ngachanan eklato, etalinga-anam nan achi on-isowan nan manngoran. Fiasa-om kasin nan kali, ela-om nan achi on-isowan nan leta.

Ela-om nan eklato asnan osa ay page. Asnan na-oy eklato wacha nan chowa ay kali. Fiasa-om nan kali, angkiay togkiawom nan chiyoy kali ay ngachan nan eklato.



akop

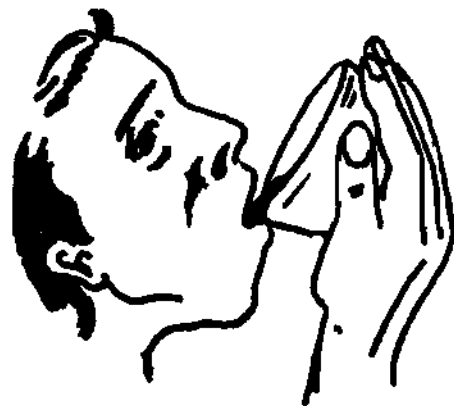

ikop



ikop

akop



akop

ikop



ikop

akop



akop

ikop



tofo

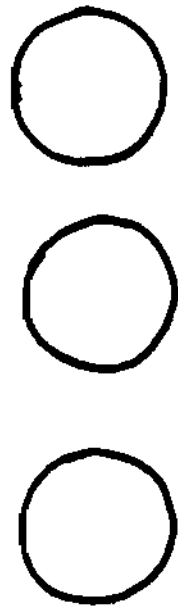

toro



toro

tofo



tofo



toro



toro

tofo



tofo

toro



owab

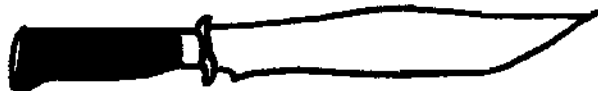

owas



owas

owab

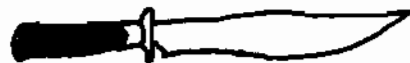

owab

owas



owas

owab



owab

owas

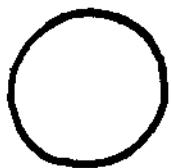

chowa

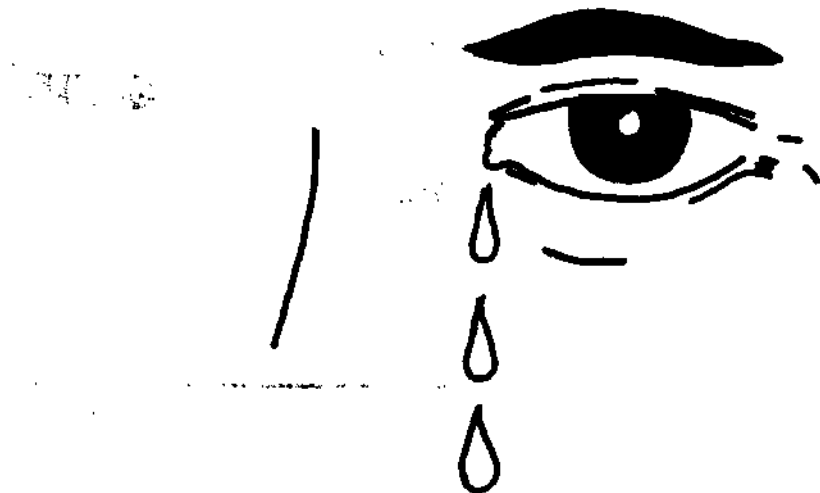

lowa



lowa



chowa



chowa

lowa



lowa

chowa



chowa



lowa

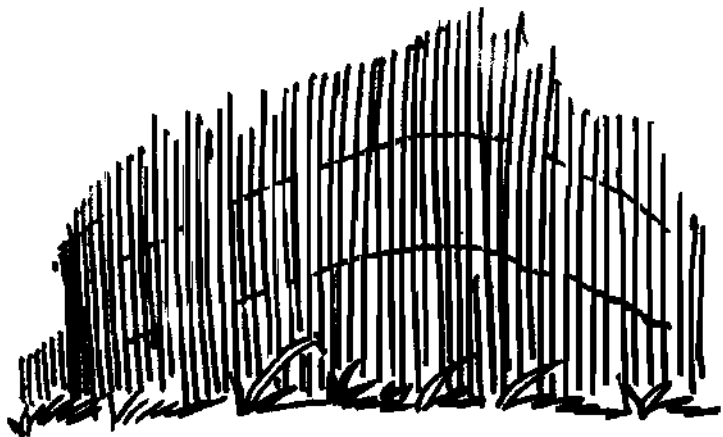

arad

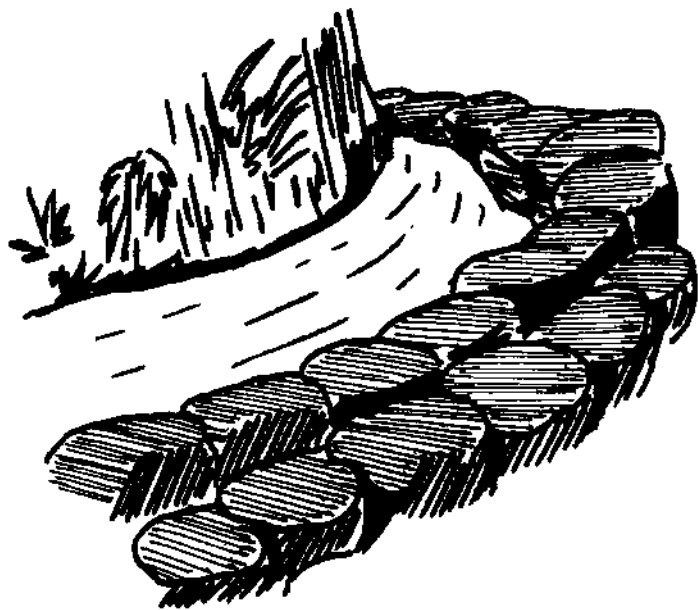

arak



arak

arad



arad

arak



arak

arad



arad

arak

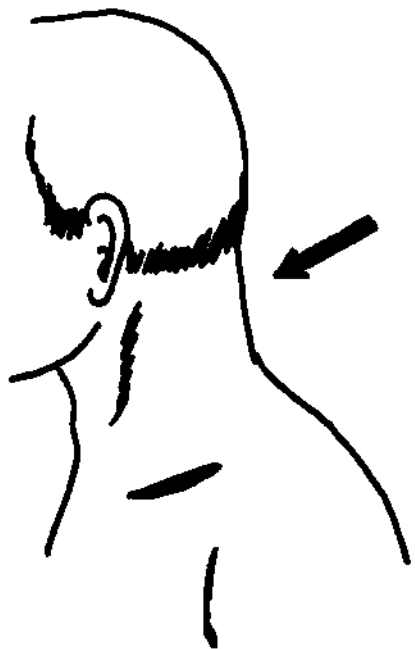

epok

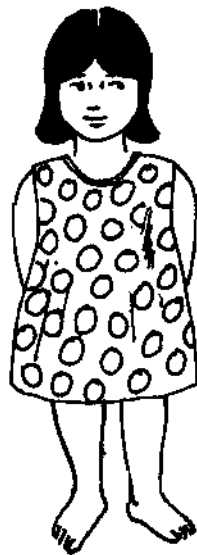

apok



apok

epok



epok

apok

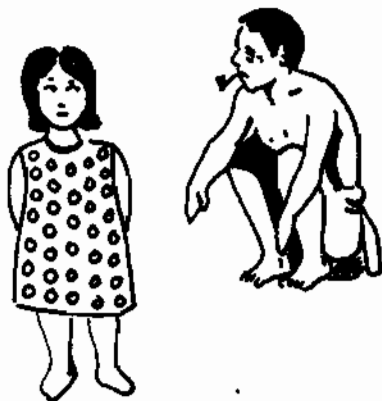

apok

epok



epok

apok



hana

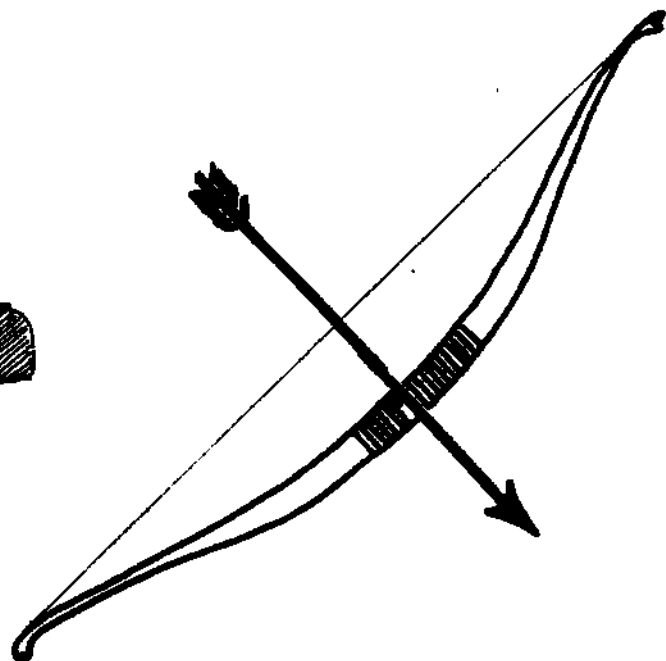

pana



pana

hana



hana

pana

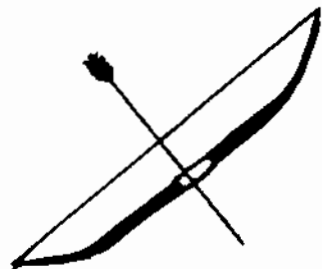

pana

hana



hana

pana



inga



onga



onga

inga



inga

onga



onga

inga



inga

onga

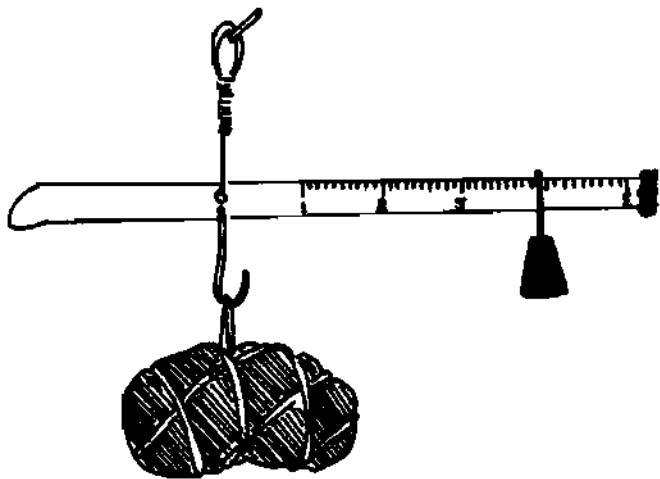

kilo



chilo

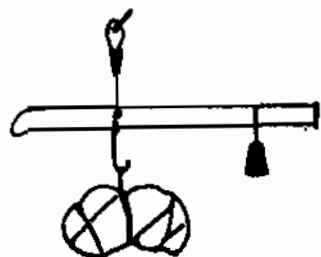

chilo

kilo



kilo

chilo



chilo

kilo

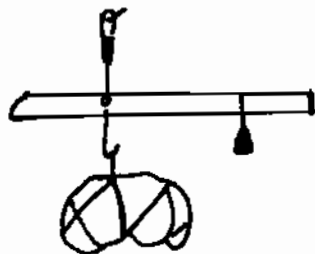

kilo

chilo

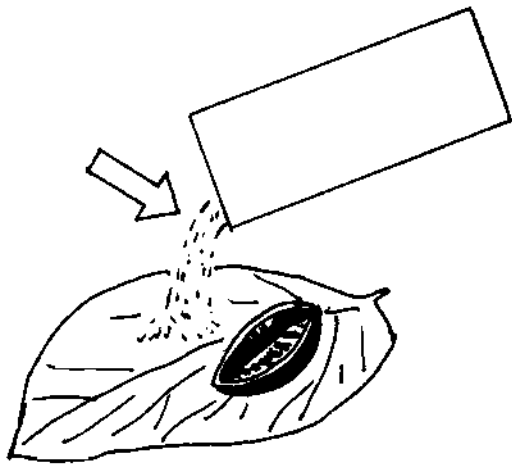

apog



apor

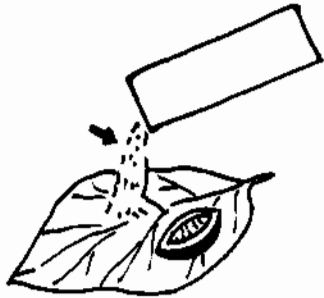

apor

apog



apog

apor



apor

apog

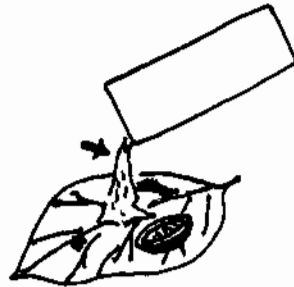

apog

apor

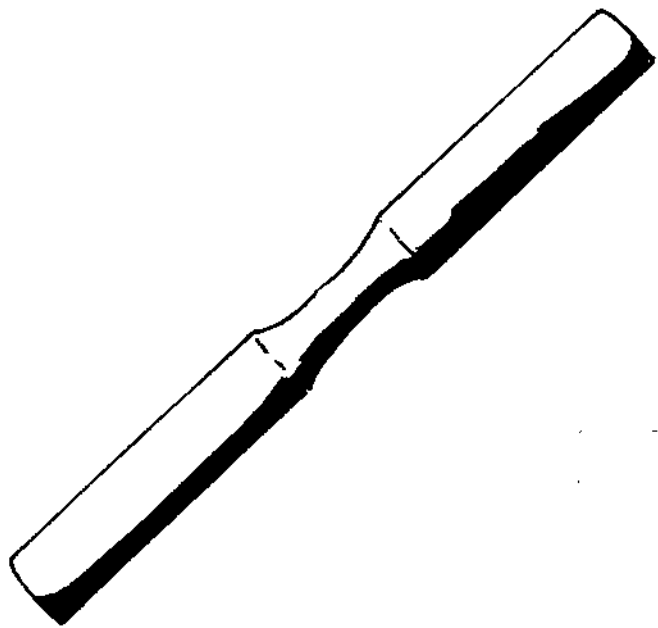

or-o



orpo

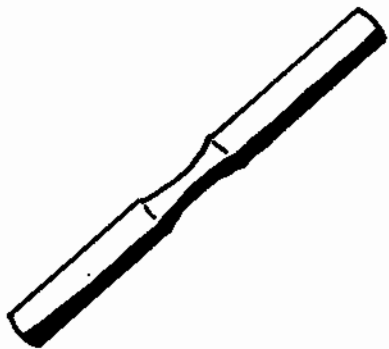

orpo

or-o



or-o

orpo



orpo

or-o

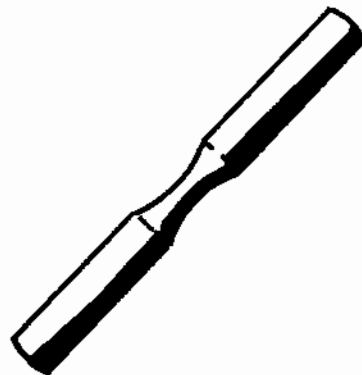

or-o

orpo

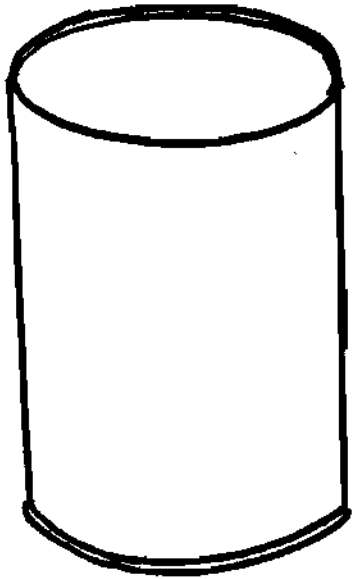

lata

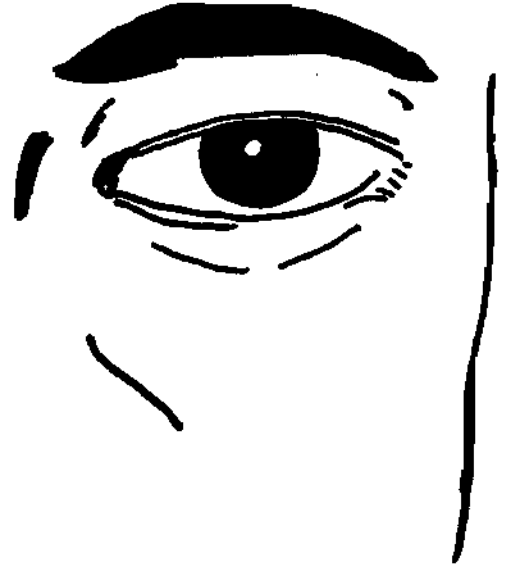

mata

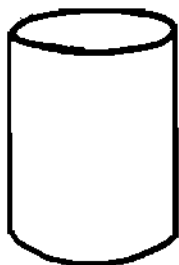

mata

lata



lata

mata



mata

lata



lata

mata



sokor

5578

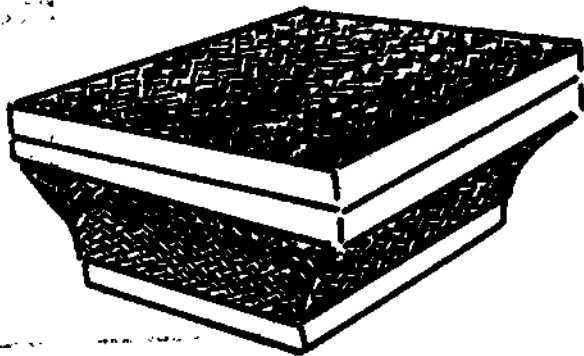

55

sokop



sokop

sokor



sokor

sokop



sokop

sokor



sokor

sokop

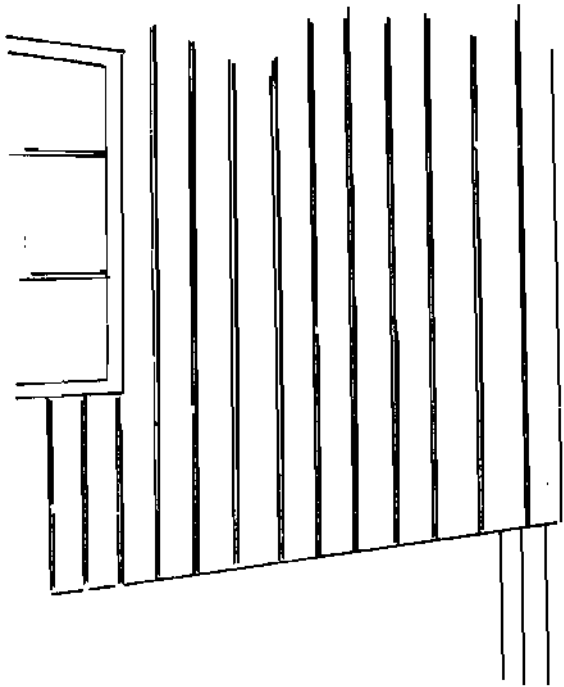

okom

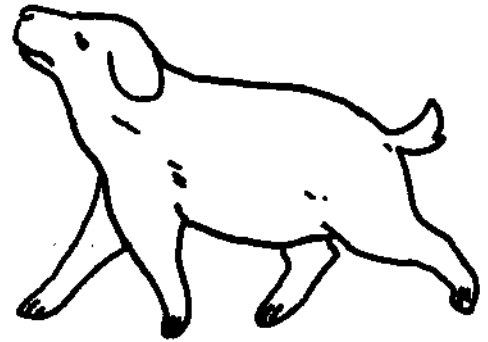

okun

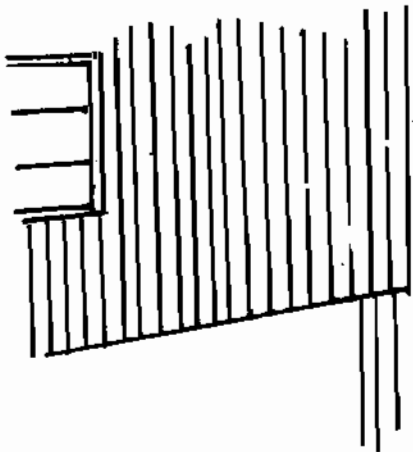

okun

okom



okom

okun



okun

okom

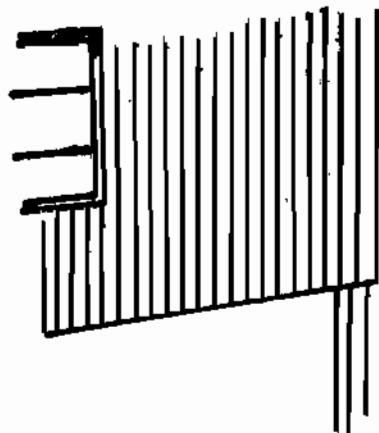

okom

okun

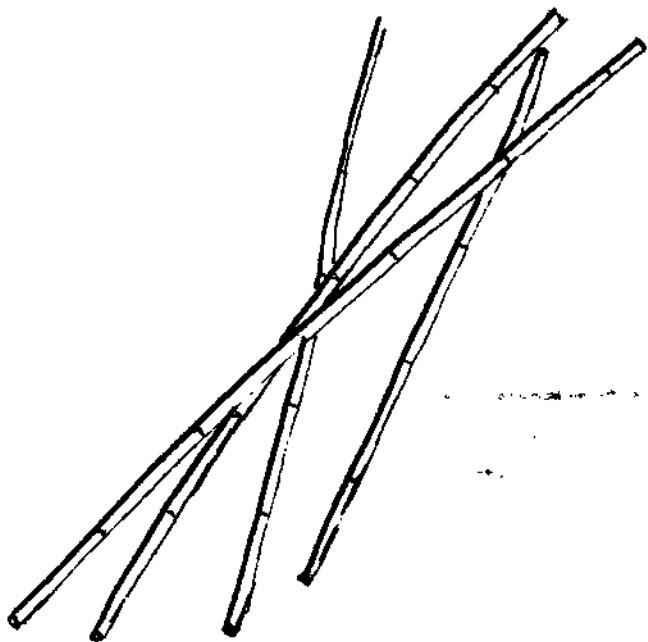

nono



chono

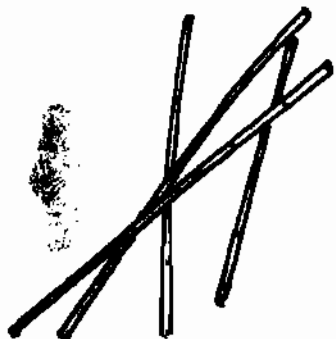

chono

nono



nono

chono



chono

nono

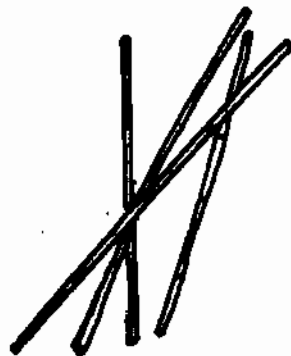

nono

chono

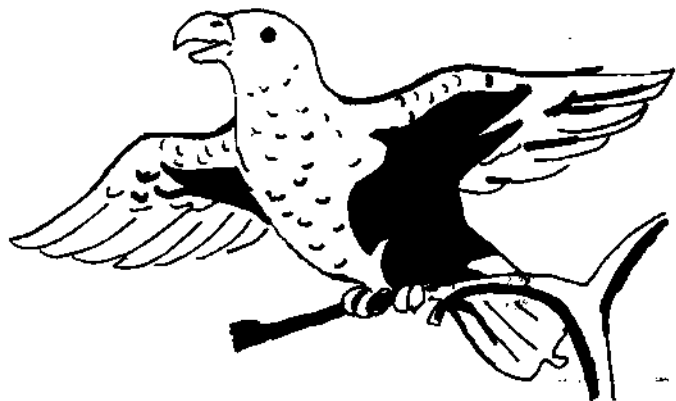

olis

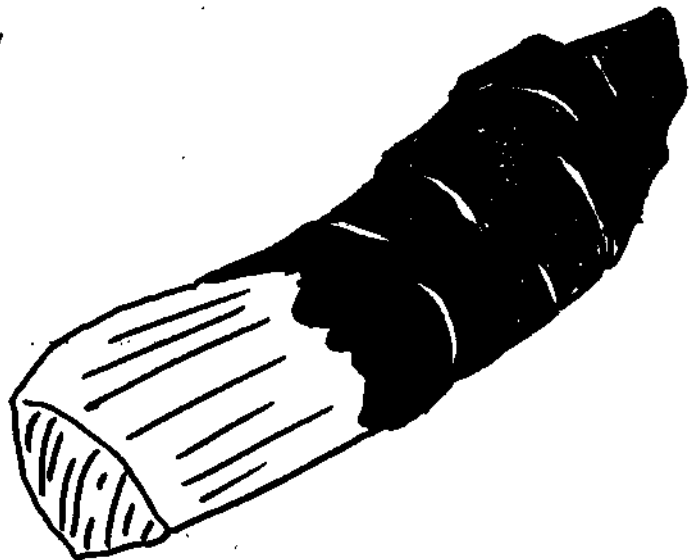

oling

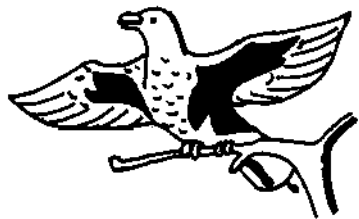

oling

olis



olis

oling



oling

olis



olis

oling

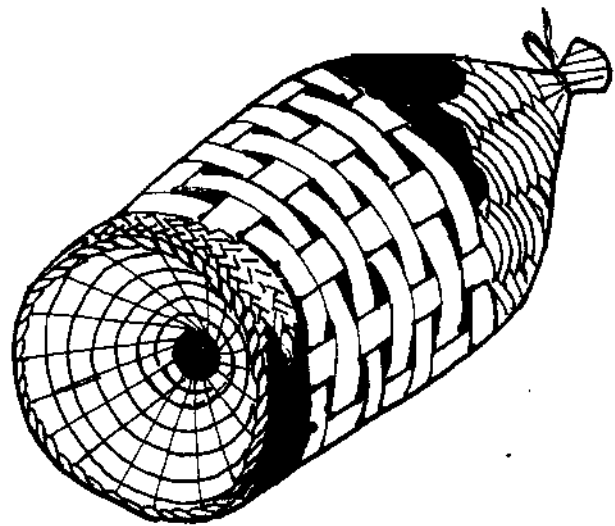

ofor

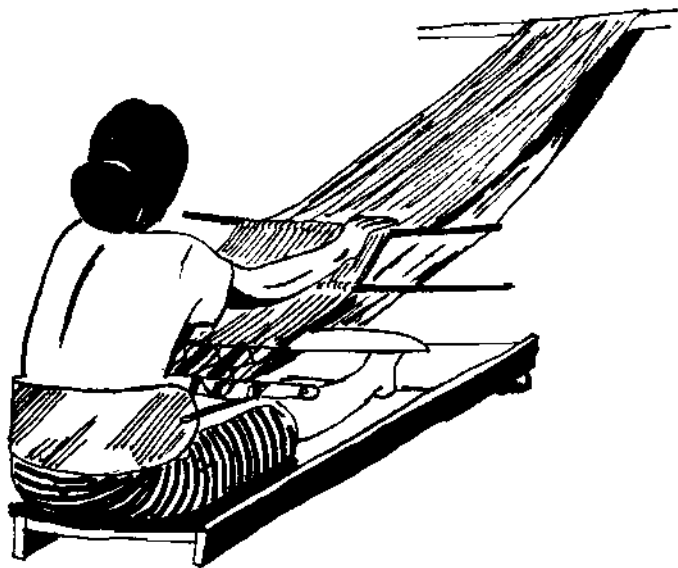

afor



afor

ofor



ofor

afor



afor

ofor



ofor

afor

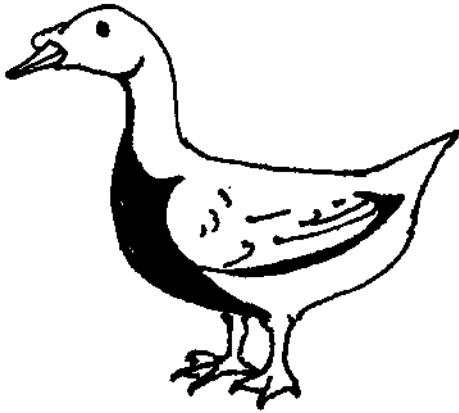

papa

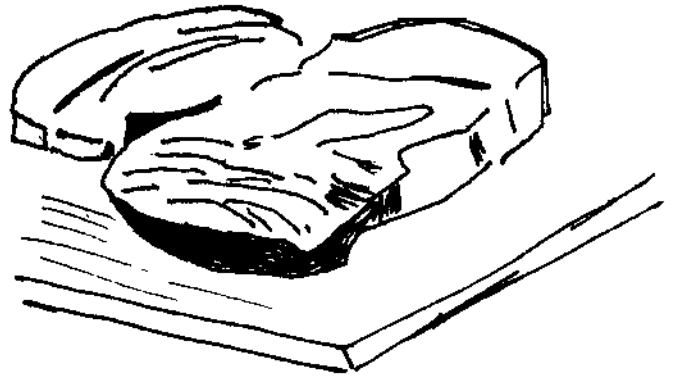

tapa

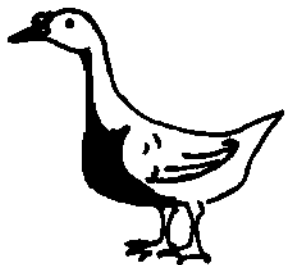

tapa

papa



papa

tapa



tapa

papa

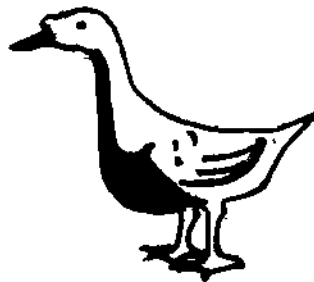

papa

tapa



siko

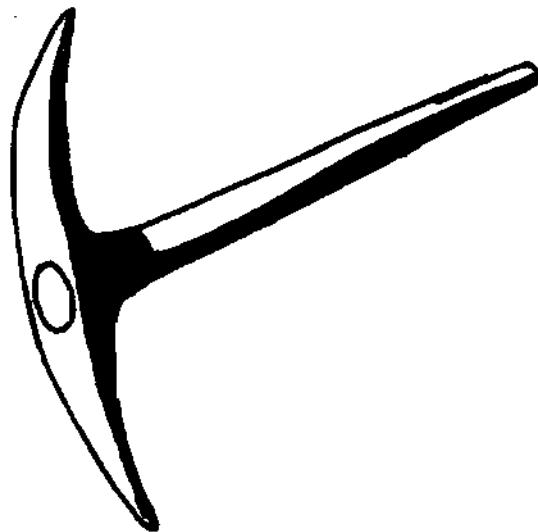

piko



piko

siko



siko

piko



piko

siko



siko

piko

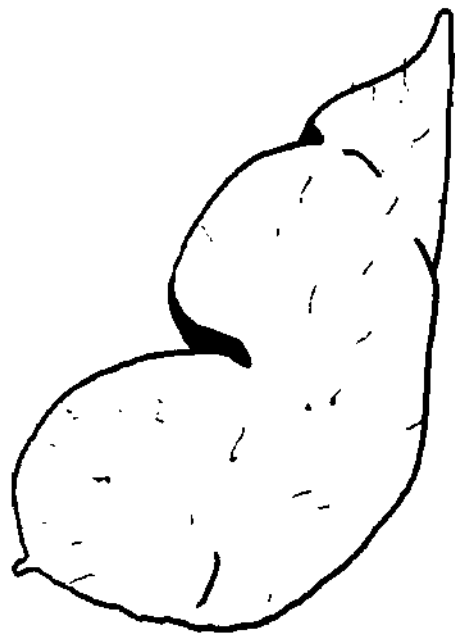

toki



soki

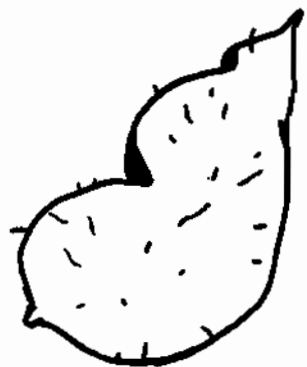

soki

toki



toki

soki



soki

toki

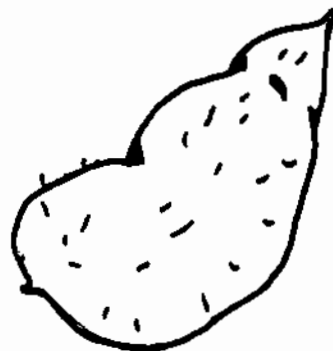

toki

soki



ochun



ochan



ochan

ochun

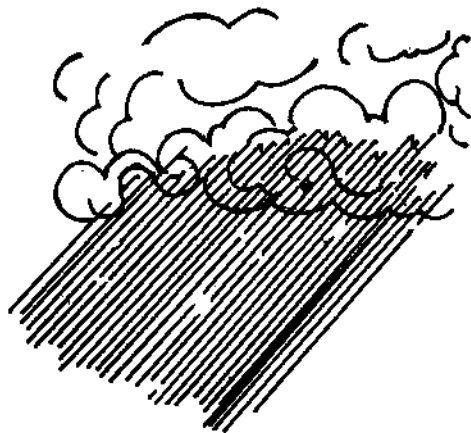

ochun

ochan

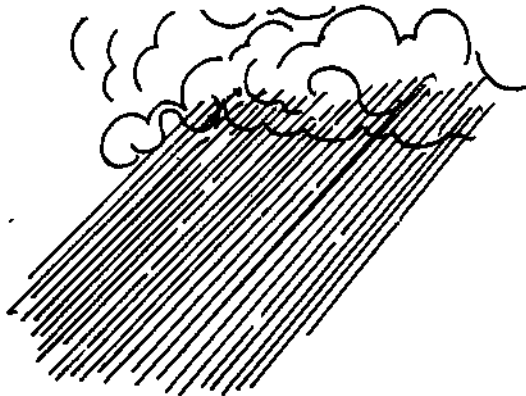

ochan

ochun



ochun

ochan



wangwang



kangkang



kangkang

wangwang



wangwang

kangkang



kangkang

wangwang



wangwang

kangkang

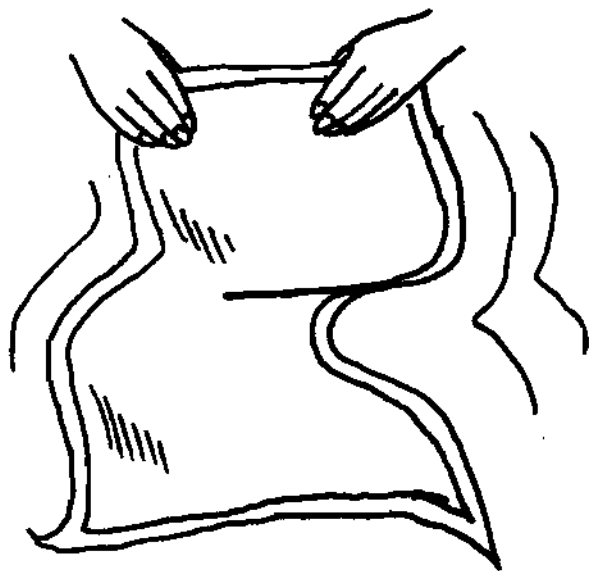

yagyag



tagtag



tagtag

yagyag

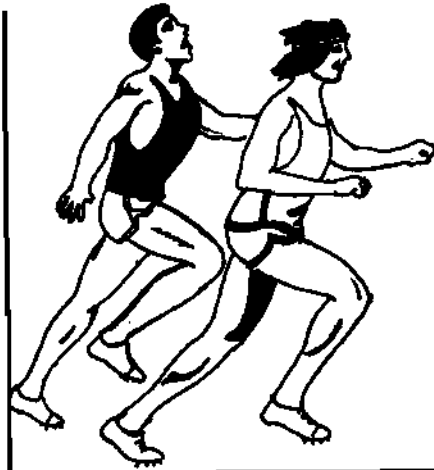

yagyag

tagtag

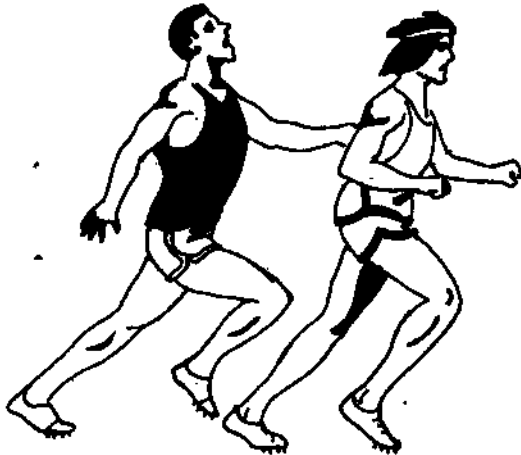

tagtag

yagyag



yagyag

tagtag



aso

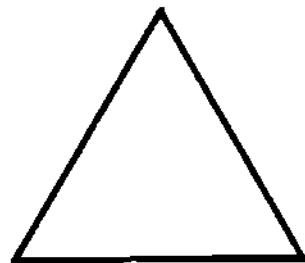
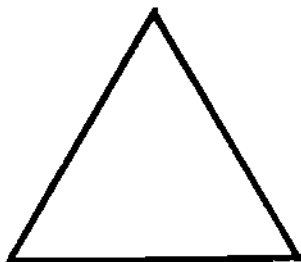

iso



iso

aso



aso

iso



iso

aso



aso

iso



afor



akor

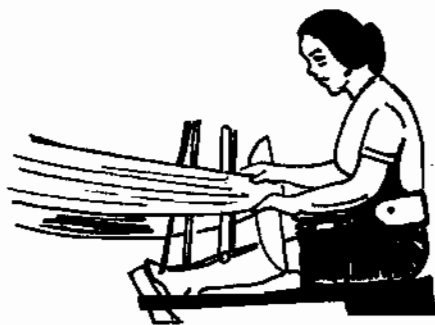

akor

afor



afor

akor



akor

afor

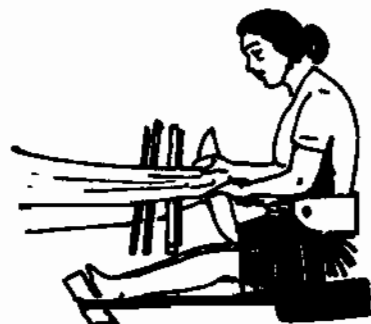

afor

akor



otob

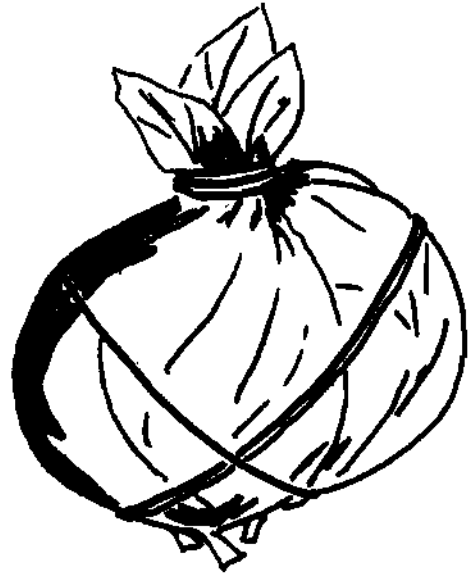

otom



otom

otob



otob

otom



otom

otob



otob

otom

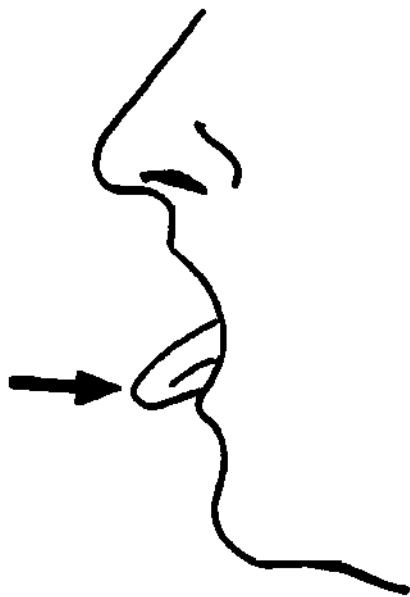

chila



fila



fila

chila



chila

fila



fila

chila



chila

fila

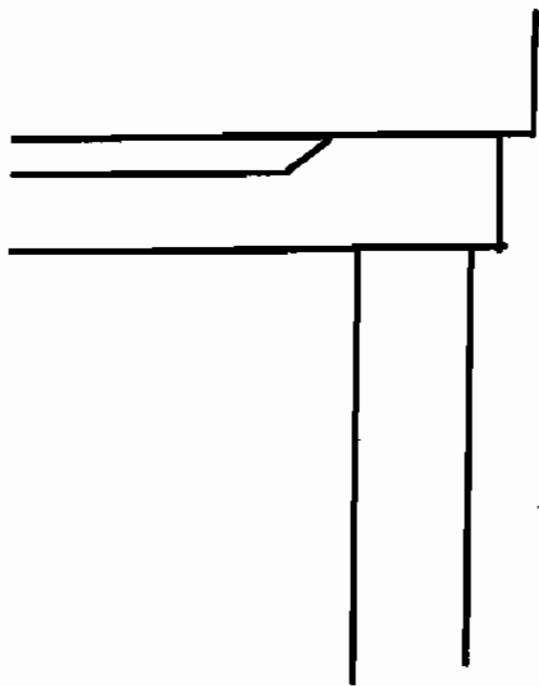

tokud

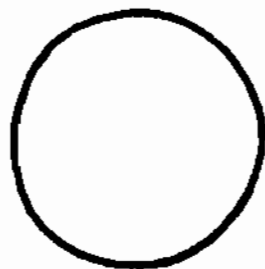
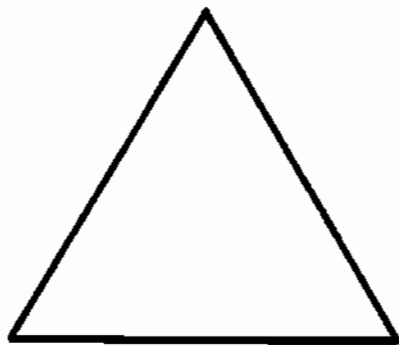

tokun

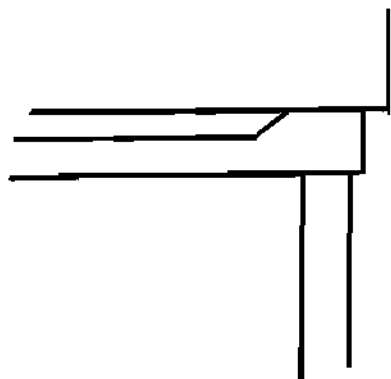

tokun

tokud



tokud

tokun



tokun

tokud

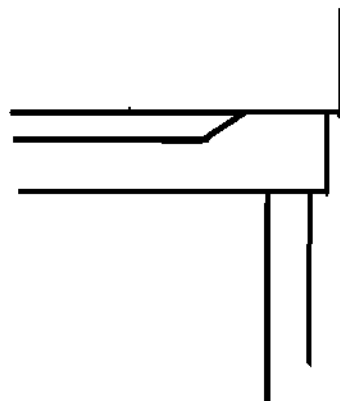

tokud

tokun

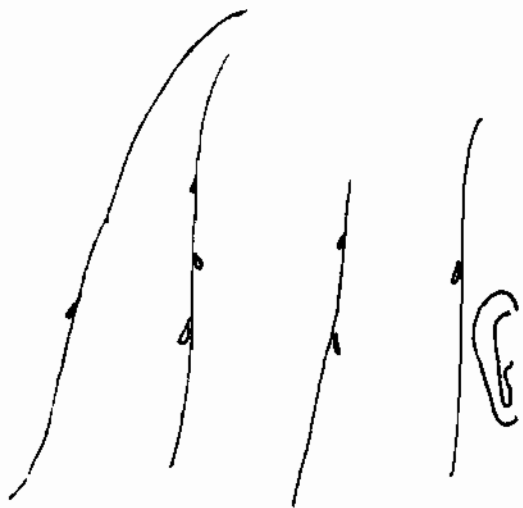

elet

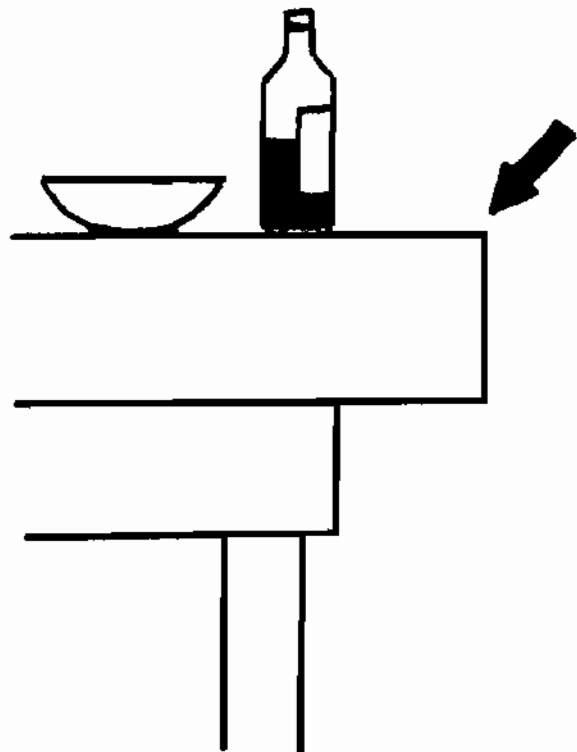

olet



olet

elet

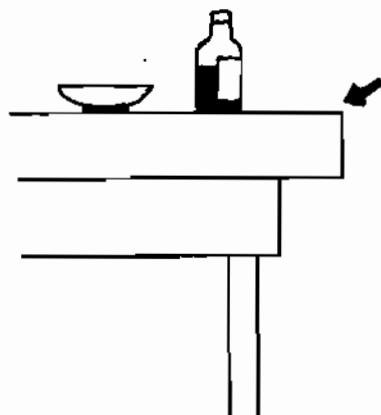

elet

olet

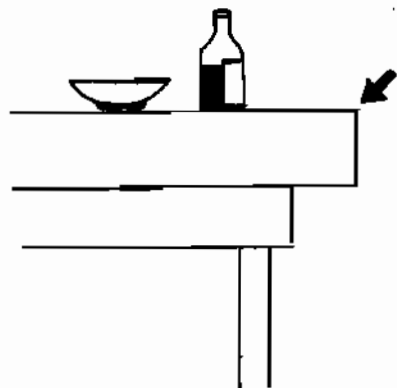

olet

elet



elet

olet



soki



soka



soka

soki



soki

soka



soka

soki



soki

soka

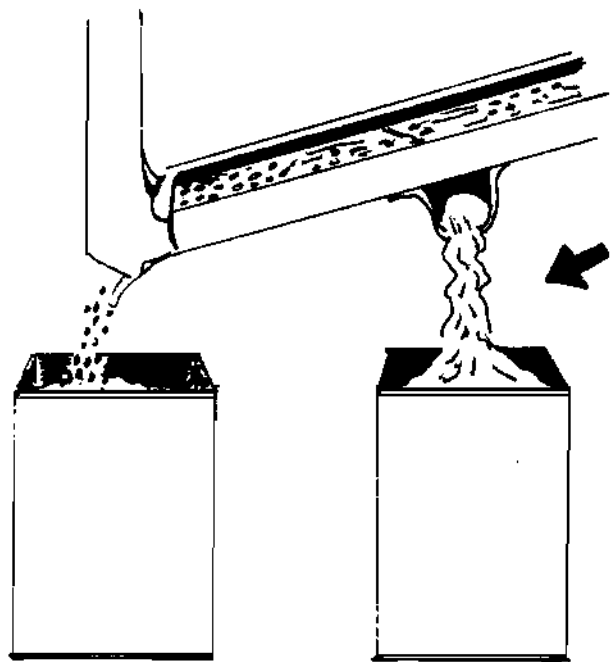

opak

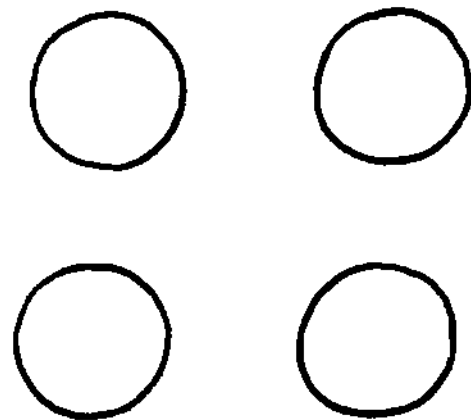

opat

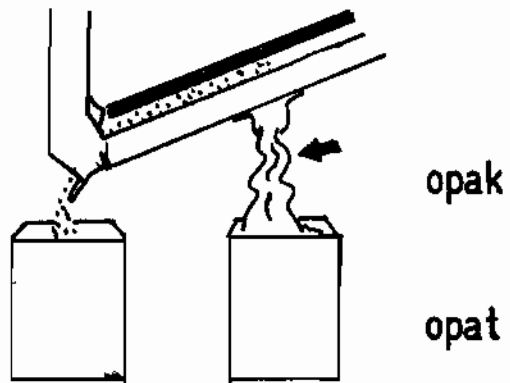
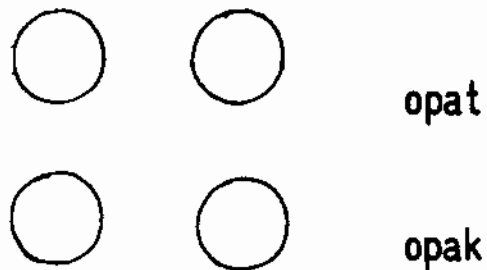
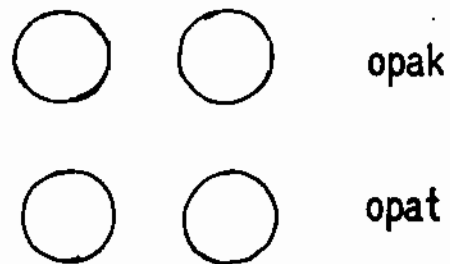
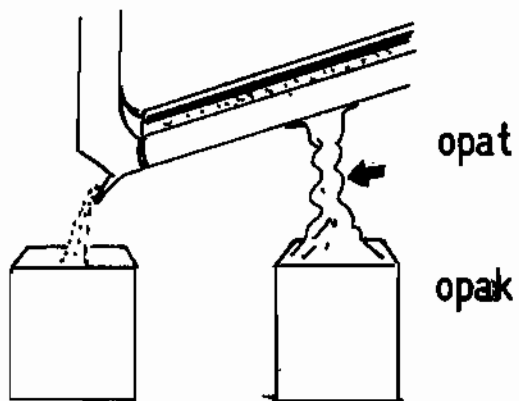

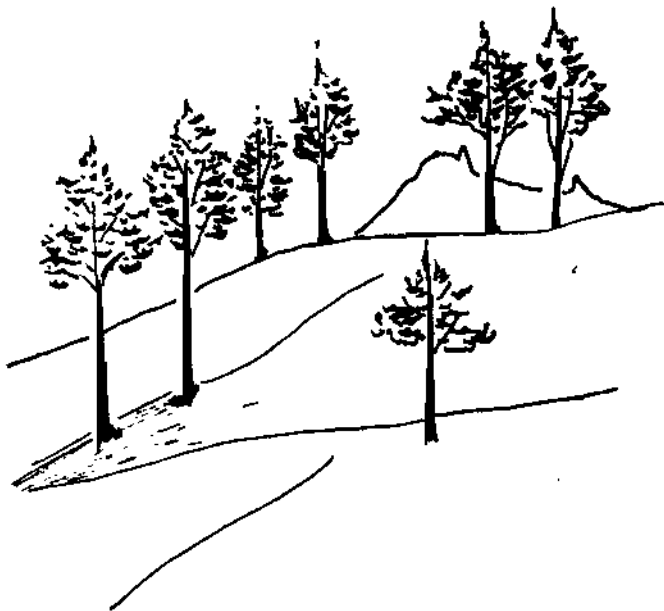

filig

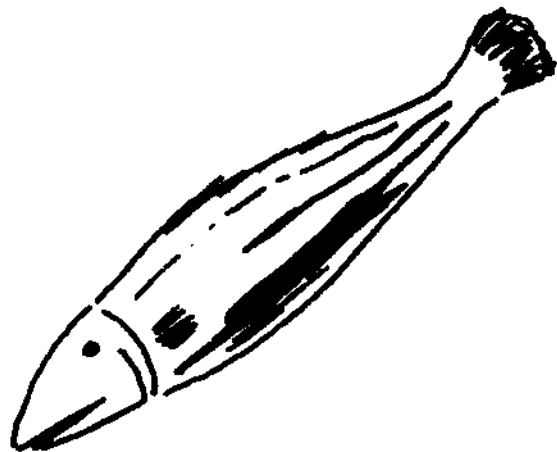

filis





e-et

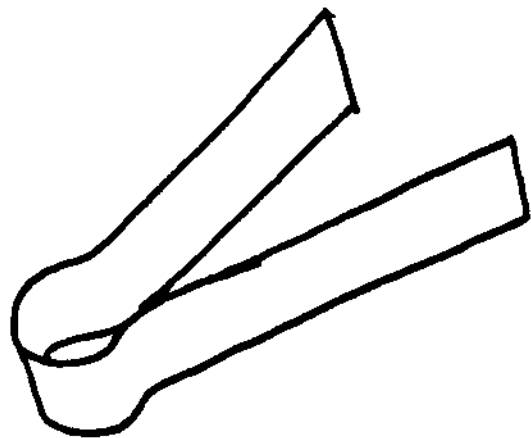

epet

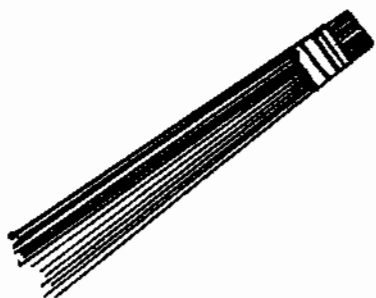

epet

e-et

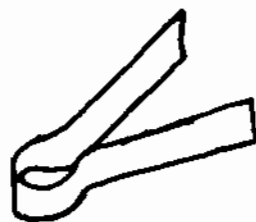

e-et

epet

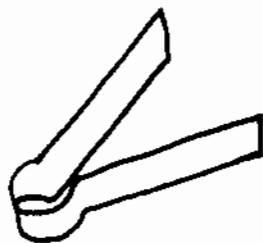

epet

e-et

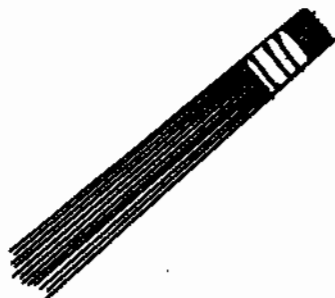

e-et

epet



lako



sako



sako

lako



lako

sako

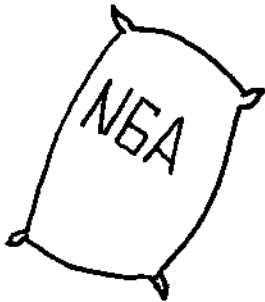

sako

lako



lako

sako

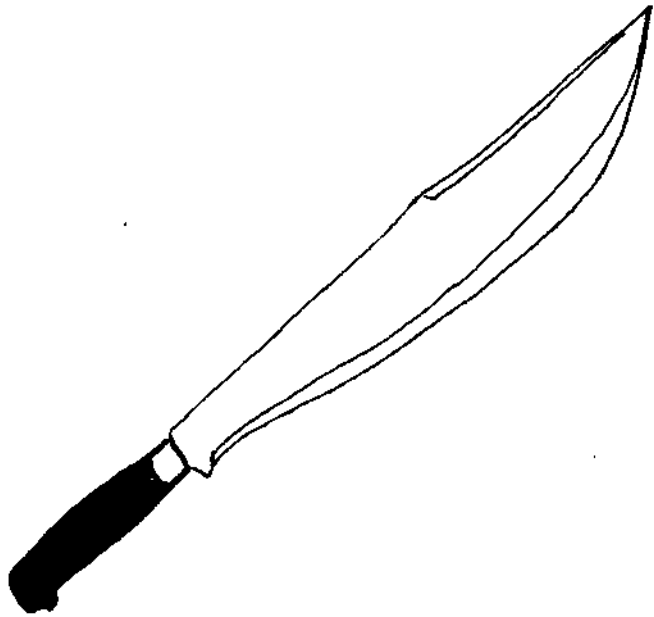

chorus

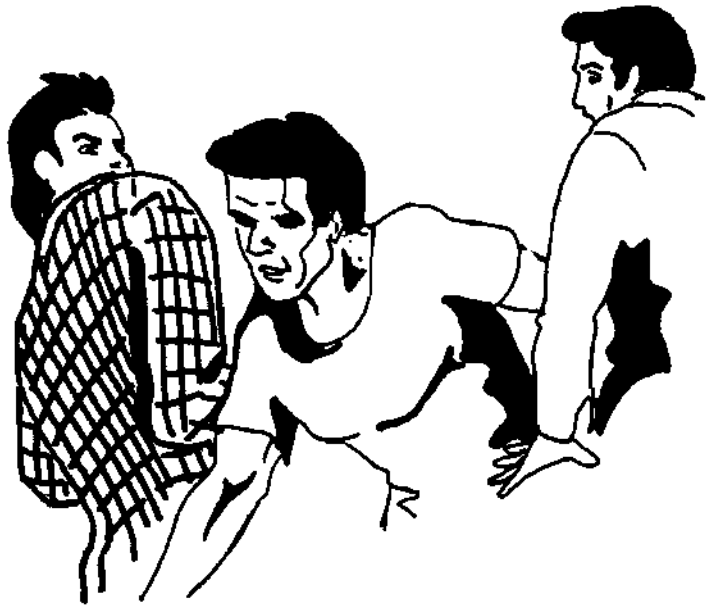

chokus

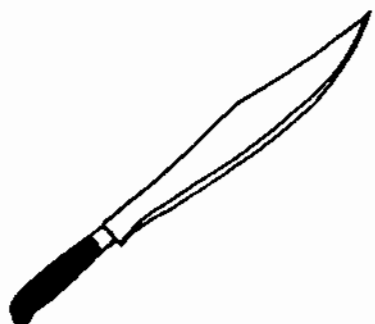

chokus

chorus

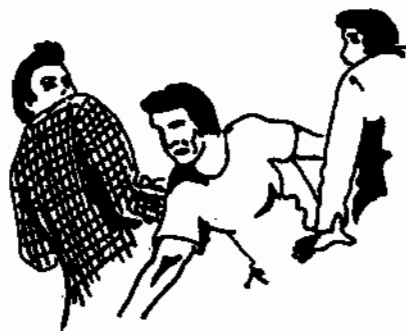

chorus

chokus

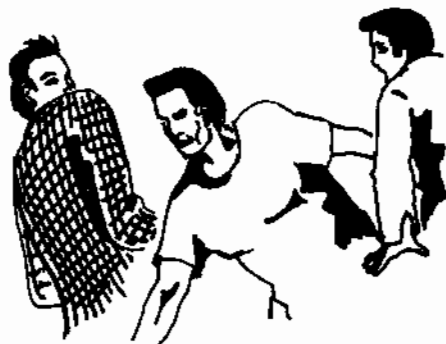

chokus

chorus

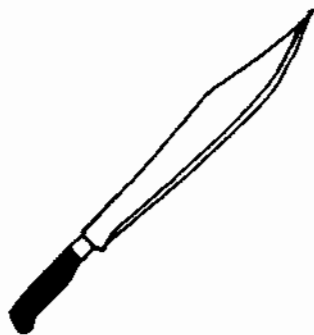

chorus

chokus

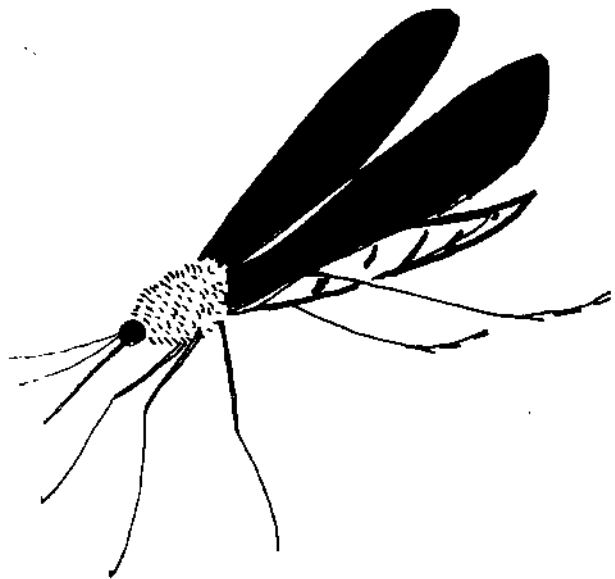

emok

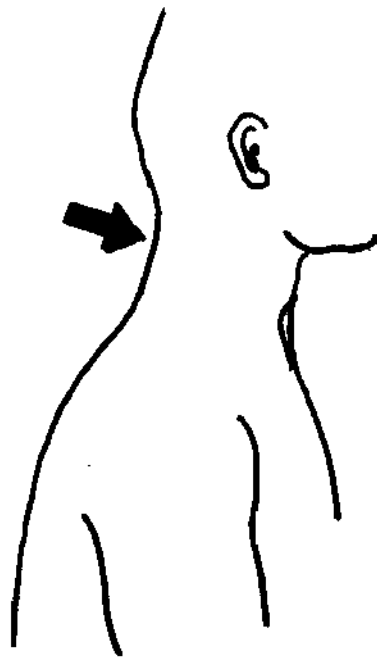

epok



epok

emok



emok

epok



epok

emok



emok

epok



siyan



siyam

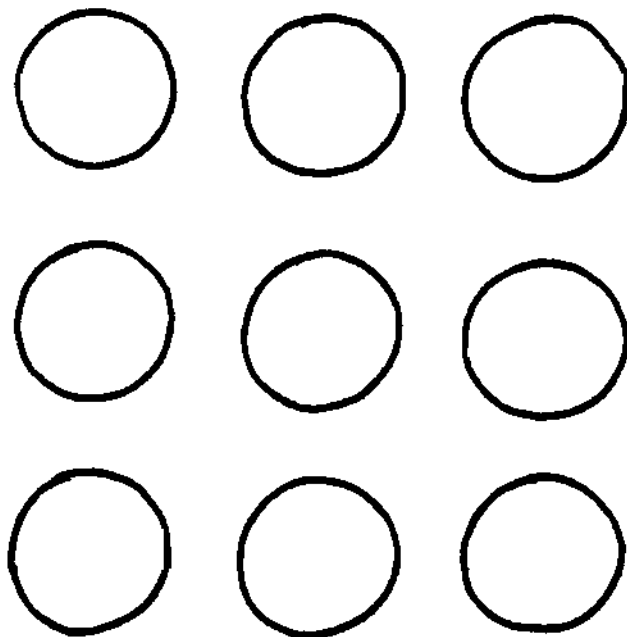



siyam

siyam

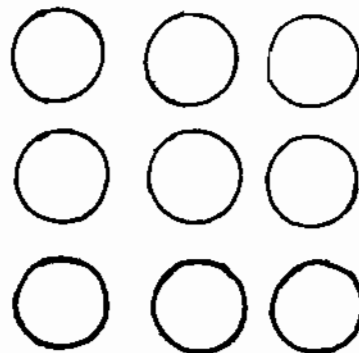

siyan

siyam

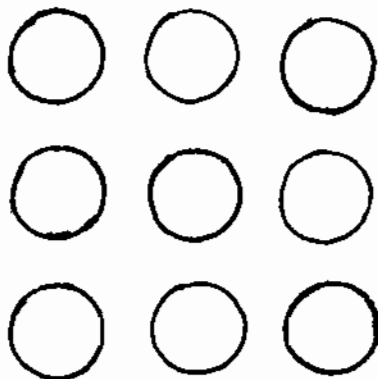

siyam

siyam



siyan

siyam

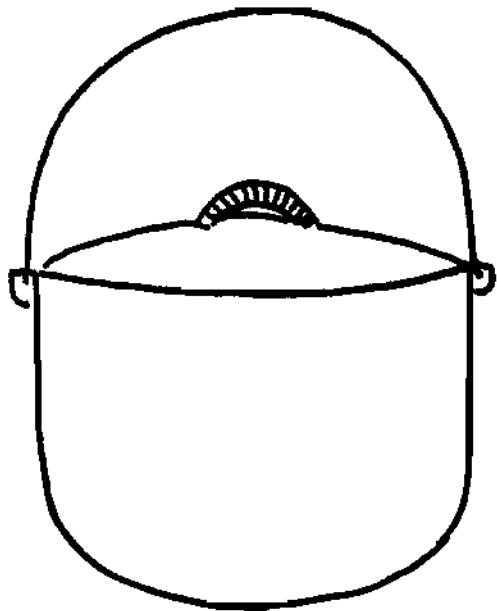

fianga



fiaka

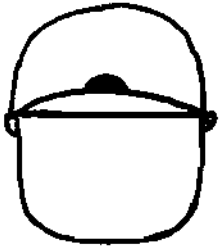

fiaka

fianga



fianga

fiaka



fiaka

fianga



fianga

fiaka



oma



ama

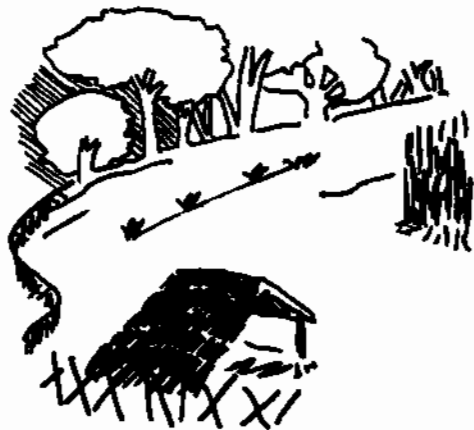

ama

oma



oma

ama



ama

oma



oma

ama

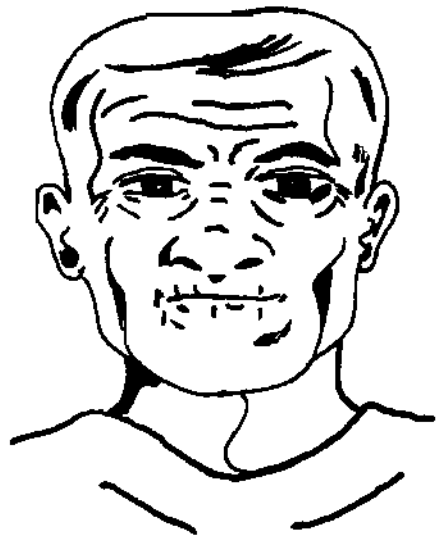

apo

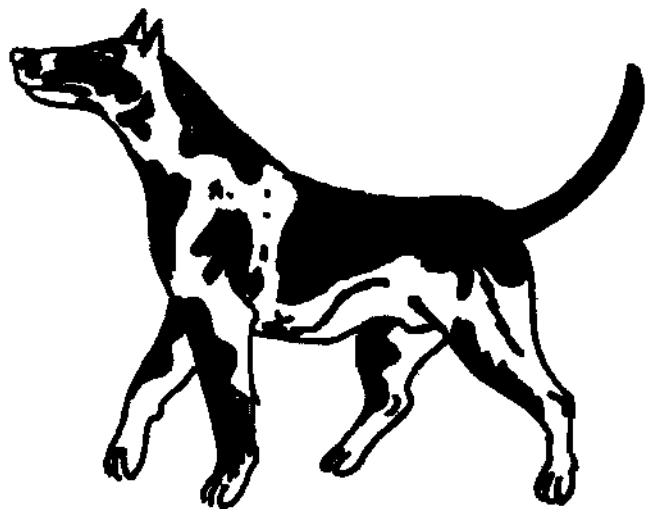

aso



aso

apo

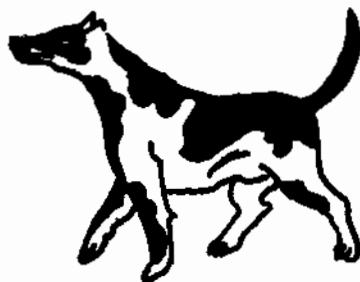

apo

aso



aso

apo



apo

aso

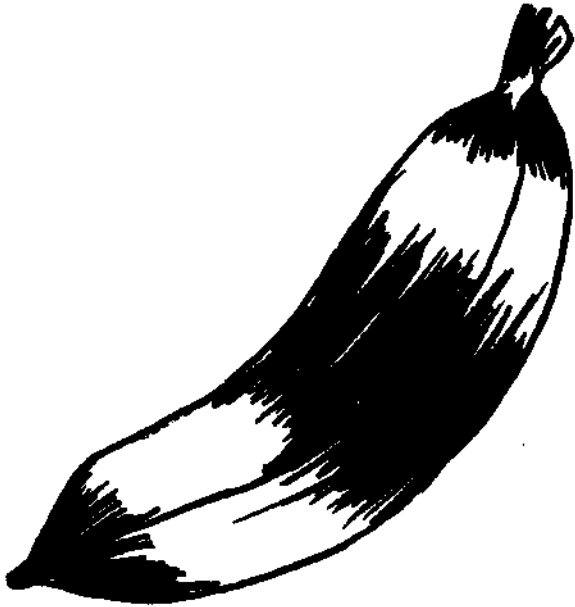

safia

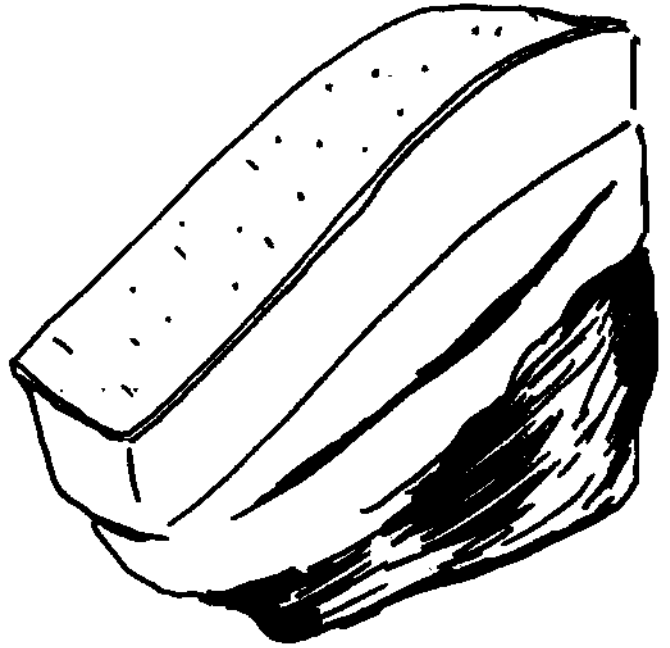

tafia



tafia

safia



safia

tafia



tafia

safia



safia

tafia



motun

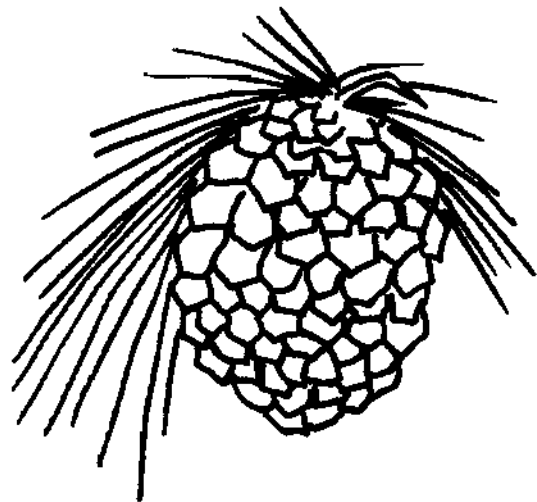

mokun



mokun

motun



motun

mokun



mokun

motun



motun

mokun

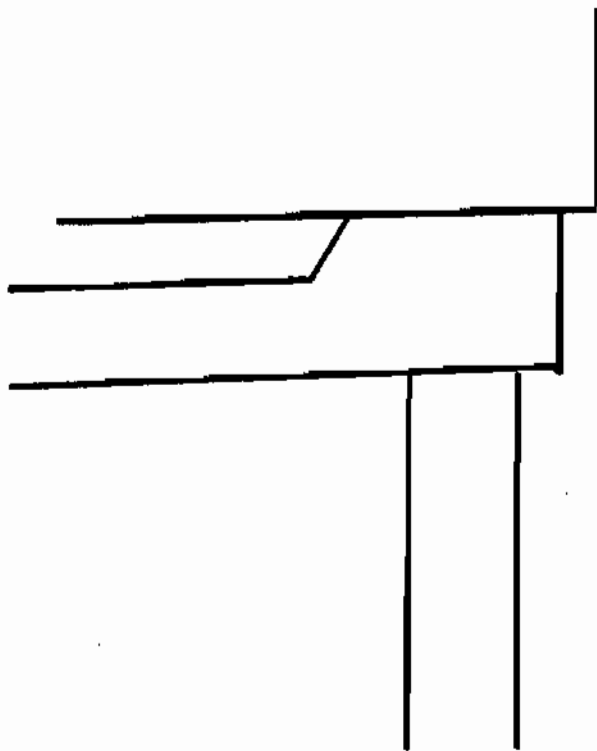

tokud

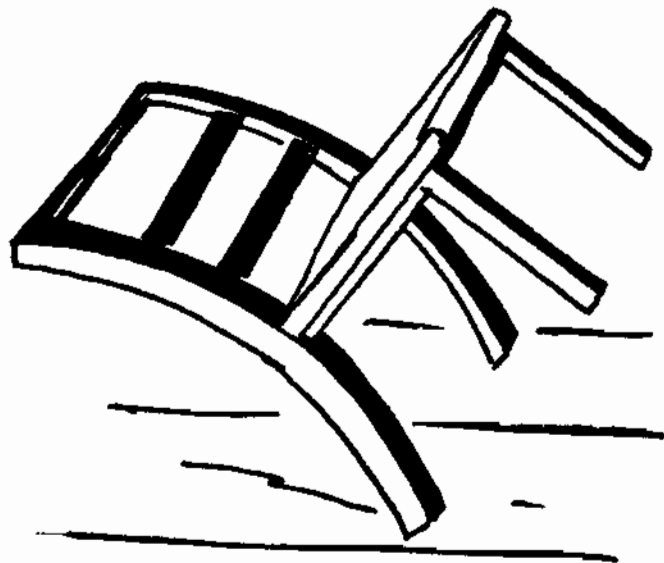

tokad

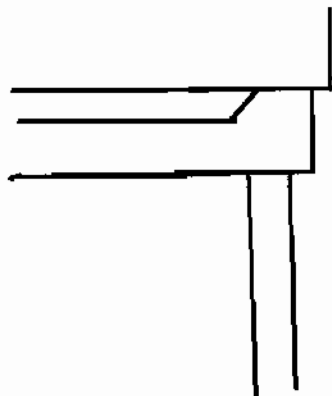

tokad

tokud

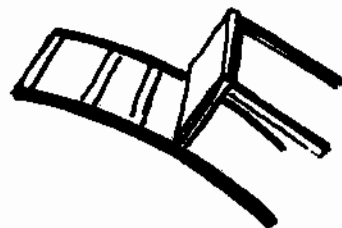

tokud

tokad



tokad

tokud

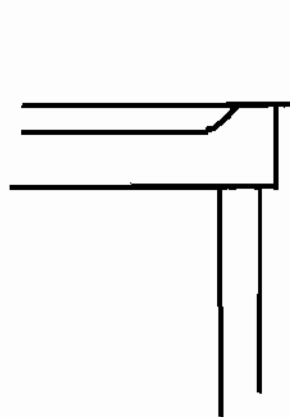

tokud

tokad

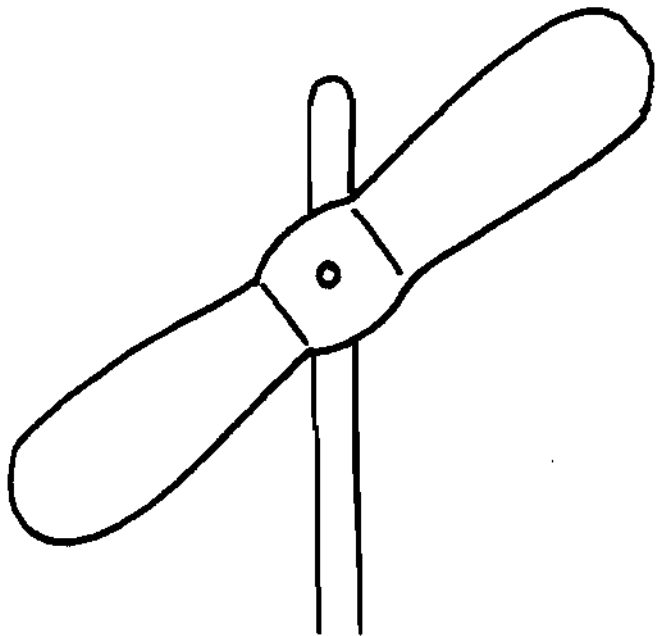

widwid

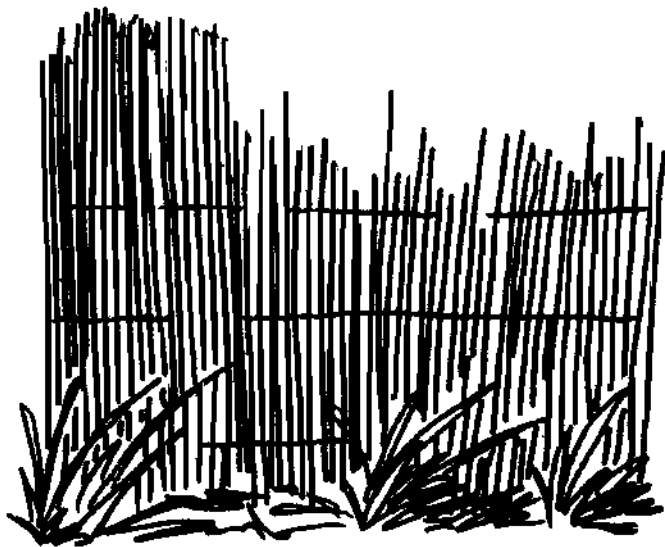

pidpid

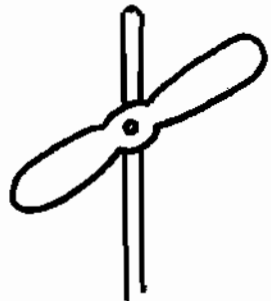

pidpid

widwid



widwid

pidpid



pidpid

widwid

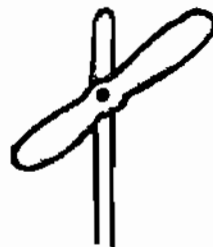

widwid

pidpid

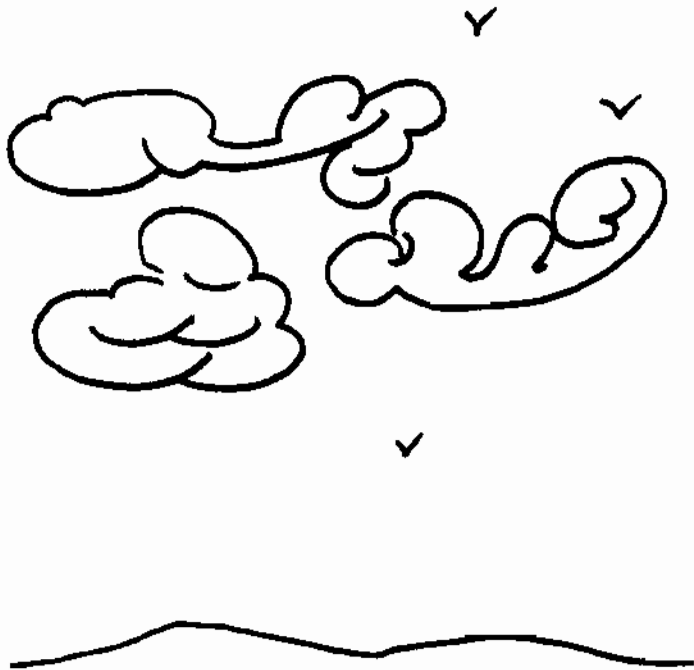

chaya

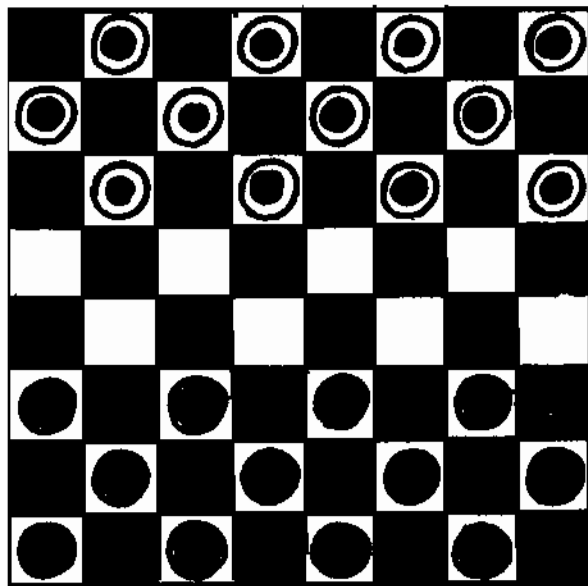

chama

