

Some Notes on the Information Structure and Discourse Features of 1 Corinthians 1-4

**Stephen H. Levinsohn
SIL International**

© 2009 by SIL International

INTRODUCTION

I use the notes in this file during the second half of ‘Discourse for Translation’ workshops run by SIL International. During the first half of each workshop, participants learn about information structure (NARR §0.1—see below) and discourse features of natural languages that are of particular relevance to Bible translation.

The materials used to teach these features (NARR and NonNarr) are available online (see below for details) and are an essential prerequisite to understanding the terminology used in these notes. Whenever you see a reference to ‘NARR’ or to ‘NonNarr’ in these notes, I recommend that you look up the relevant section, so that you can understand how I am using the term concerned. If you turn to NARR §0.1, for example, you will find a definition of the term ‘information structure’ (“the interaction of sentences and their contexts”—Lambrecht 1994:9). Similarly, you will encounter a reference on p. 3 to NonNarr §2.2.2, where you will find a discussion of what constitutes a ‘message framework’.

The file contains flow-charts of the argument structure of each sub-section, together with comments on the information structure and discourse features of each verse.

It is my prayer that these notes will be a helpful tool for all who exegete and translate this book into the heart language of a people group for whom Christ died and rose again.

References

- Lambrecht, Knud. 1994. *Information Structure and Sentence Form: Topic, Focus, and the Mental Representation of Discourse Referents*. New York: Cambridge University Press.
- NARR: Levinsohn, Stephen H. 2008a. *Self-Instruction Materials on Narrative Discourse Analysis*. Online at <http://www.sil.org/~levinsohns>.
- NonNarr: Levinsohn, Stephen H. 2008a. *Self-Instruction Materials on Non-Narrative Discourse Analysis*. Online at <http://www.sil.org/~levinsohns>.

Notes

1:1-3 Greeting

1:1-3 constitute the **introduction**, which ‘relates the author to the recipients and gives a greeting’. However, 1:4-9 lead up to the exhortation of 10, so I do NOT consider them to be part of the ‘message framework’ (NonNarr §2.2.2).

1:1 *Paul, called to be an apostle of Christ Jesus by the will of God, and our brother Sosthenes* (Παῦλος κλητὸς ἀπόστολος Χριστοῦ Ἰησοῦ διὰ θελήματος θεοῦ καὶ Σωσθένης ὁ ἀδελφός). It is normal in Greek for referents to be introduced without the article (DFNTG §9.2.1 p. 150).

1:2a *To the church of God that is in Corinth* (τῇ ἐκκλησίᾳ τοῦ θεοῦ τῇ οὔσῃ ἐν Κορίνθῳ). The articular participial clause τῇ οὔσῃ ἐν Κορίνθῳ (*the being in Corinth*) functions like an attributive adjective (Wallace 1996:618) and may be translated by a relative clause (ibid. p. 307), which in this instance is restrictive (NARR §10.3.3).¹

1:2b *to those who are sanctified in Christ Jesus* (ἡγιασμένοις ἐν Χριστῷ Ἰησοῦ). ἡγιασμένοις (*to sanctified ones*) is a perfect participle (a ‘past event whose consequences stretch into the present time’—UBS p.5).

ἐν Χριστῷ Ἰησοῦ (*in Christ Jesus*—without the article) is probably a frozen form.²

1:2c *called to be saints* (κλητοῖς ἁγίοις).

1:2d *together with all those who in every place call on the name of our Lord Jesus Christ* (σὺν πᾶσιν τοῖς ἐπικαλουμένοις τὸ ὄνομα τοῦ κυρίου ἡμῶν Ἰησοῦ Χριστοῦ ἐν παντὶ τόπῳ).

1:2e *theirs and ours* (αὐτῶν καὶ ἡμῶν).

1:3 *Grace to you and peace* (χάρις ὑμῖν καὶ εἰρήνη). It is normal in Greek for the first part of a coordinative focal constituent to begin a proposition and be separated from the second part by the verb or another constituent (DFNTG §4.4.1 pp. 57f).³ There is no need for the Greek order to be reproduced in languages where such an order is marked (e.g. English!).

from God our Father and the Lord Jesus Christ (ἀπὸ θεοῦ πατρὸς ἡμῶν καὶ κυρίου Ἰησοῦ Χριστοῦ). The lack of the article is consistent with the referents being given focal prominence (though the whole greeting could be formulaic) (NonNarr §6.1.3).

1:4-9 Thanksgiving

‘Asyndeton is typically found at the’ transition ‘from the opening salutation to the body of each letter’ (DFNTG §7.2 p. 119). The shift of mood from an implied optative (*May...*) to the indicative (NonNarr §8.11) also provides supporting evidence for the beginning of a new unit or sub-unit at 1:4.

4-9 are a ‘Conciliatory preamble’ (Meyer 1890:13) and **lead up** to the exhortation of 1:10. In other words, these verses could be said to have **inductive** style, with the hortatory thesis in final position

¹ When not otherwise specific, ‘sec.’ references are to my 1CorGk lecture notes.

² The following comments about the distribution of *Christ Jesus* versus *Jesus Christ* in 1 Timothy may be applicable also to 1 Corinthians. ‘With reference to the discussion in *TrNotes* and *UBS*, it is unlikely that there is a difference in meaning between *Jesus Christ* and *Christ Jesus* in 1 Tim. The variations appear to be determined by the nature of the NP in which the expressions occur.

- ‘The only time that *Jesus Christ* occurs in 1 Tim is in the expression *the NOUN of the Lord our Jesus Christ* (6:3, 14), where the head NOUN (*healthy words* [3], *the appearing* [14]) is at least as important as the modifier.
- ‘*Christ Jesus* (without the article) occurs both in the focus of a proposition (e.g. 1:1,2) and as the topic (e.g. 1:15,16), so appears to be a **frozen form** (see especially the coordinated phrase in 6:13, where the reference to God is articular). When followed by another modifier, the article always occurs (e.g. *Christ Jesus the lord our* (Χριστοῦ Ἰησοῦ τοῦ κυρίου ἡμῶν—1:2,12; see also 1:1, 2:5 & 6:13). This contrasts with *God \emptyset Saviour our* (θεοῦ σωτήρος ἡμῶν—1:1).’

³ Contrast Morris 1991:37f, who says, ‘The word order is significant’.

(NonNarr §§2.3, 2.4). 4-8 are one long sentence in the Greek, with *I give thanks* as its main verb (*TrNotes*).

1:4a *I give thanks to my God always for you* (Εὐχαριστῶ τῷ θεῷ μου πάντοτε περὶ ὑμῶν). The order of the adjuncts suggests that *for you* is ‘more focal’ than *always*, though the adjunct of 4b is ‘more focal’ yet (*DFNTG* §3.4 p. 32).

1:4b *for the grace of God that has been given you in Christ Jesus* (ἐπὶ τῇ χάριτι τοῦ θεοῦ τῇ δοθείσῃ ὑμῖν ἐν Χριστῷ Ἰησοῦ). As in 2a, the articular participial clause τῇ δοθείσῃ ὑμῖν ἐν Χριστῷ Ἰησοῦ (*the given to you in Christ Jesus*) functions like an attributive adjective and may be translated by a restrictive relative clause.

1:5 *that/because in every way you have been enriched in him, in all speech and all knowledge* (ὅτι ἐν παντὶ ἐπλουτίσθητε ἐν αὐτῷ, ἐν παντὶ λόγῳ καὶ πάσῃ γνώσει). The connective ὅτι shows that what follows ‘interprets’ something that has already been said or implied (NonNarr §3.5.3). Here, what follows interprets *the grace of God that has been given you in Christ Jesus* (4b) by indicating ‘more specifically what aspects of “grace” ... Paul was thankful for’ (Trail 1995:20; see also *UBS* p. 10).

The DFE (‘dominant focal element’—Heimerdinger 1999:167)⁴ ἐν παντὶ (*in everything*) is proposed for extra (emphatic) prominence (NonNarr §5.2.1); ἐν παντὶ λόγῳ καὶ πάσῃ γνώσει (*in all speech and all knowledge*) is in apposition to ἐν παντὶ.

1:6 *just as the testimony of Christ was confirmed in you* (καθὼς τὸ μαρτύριον τοῦ Χριστοῦ ἐβεβαιώθη ἐν ὑμῖν). The pre-verbal subject signals a switch of topic from *you* (5).

1:7a *so that you are not lacking in any spiritual gift* (ὥστε ὑμᾶς μὴ ὑστερεῖσθαι ἐν μηδενὶ χαρίσματι). The pre-verbal subject signals a switch of topic back to *you* from *the testimony of Christ* (6). The rest of the negated proposition has default constituent order (*DFNTG* §4.1 p. 50).

1:7b *as you wait for the revealing of our Lord Jesus Christ* (ἀπεκδεχομένους τὴν ἀποκάλυψιν τοῦ κυρίου ἡμῶν Ἰησοῦ Χριστοῦ). A **post**-nuclear participial clause, so NOT necessarily backgrounded with respect to 7a.

The repetition of the key phrase τοῦ κυρίου ἡμῶν Ἰησοῦ Χριστοῦ *of our Lord Jesus Christ* in 7-9 (a longer version is used in 9) gives prominence to that phrase (NonNarr §7.7.2).

1:8a *who will also confirm you to the end* (ὃς καὶ βεβαιώσει ὑμᾶς ἕως τέλους). A non-restrictive relative clause (*DFNTG* §11.2 p. 191) used in connection with ‘sequential progression’, in which a constituent of the comment of one proposition (here, *our Lord Jesus Christ*) becomes the topic of the next (NonNarr §4.1). The relative clause may well be ‘continuative’ (*ibid.*), with 7b backgrounded with respect to 8a.

καὶ (*also*). I favour the second option listed by Trail (p. 26): *the testimony of Christ was confirmed in you* (6) and he **also** confirm you to the end. The third option (‘It has no meaning following a relative pronoun and is left untranslated’) should be interpreted as an instance of confirmation (*DFNTG* §6.2 p. 101): *you wait for the revealing of our Lord Jesus Christ* (7b) and He will **indeed** keep you until He is revealed.

1:8b *blameless on the day of our Lord Jesus Christ* (ἀνεγκλήτους ἐν τῇ ἡμέρᾳ τοῦ κυρίου ἡμῶν Ἰησοῦ [Χριστοῦ]).

1:9a *God is faithful* (πιστὸς ὁ θεός). Godet (1886(1971):59) says about the absence of any connective, ‘The asyndeton between the preceding verse and this arises from the fact that the latter is only the reaffirmation, in another form, of the same idea’. The focal complement πιστὸς (*faithful*) has been

⁴ For discussion of the DFE, which is Heimerdinger’s term for ‘the most *important* constituent of the comment’ (*DFNTG* §3.4 p. 32), see *NARR* §4.2.4.

proposed to give it extra prominence (NonNarr §5.2.1; it ‘is placed emphatically forward’—Lenski 1961:35).

1:9b *through whom you were called into fellowship of his Son, Jesus Christ our Lord* (δι’ οὗ ἐκλήθητε εἰς κοινωνίαν τοῦ υἱοῦ αὐτοῦ Ἰησοῦ Χριστοῦ τοῦ κυρίου ἡμῶν). Hoopert (1981:237) treats this non-restrictive relative clause as ‘delimitation’; i.e. ‘appositional’, adding ‘a piece of information about an already identified entity’ (DFNTG §11.2 p. 191).

1:10-4:21 Problem 1: Believers are disagreeing with one another about which leaders they should follow (TrNotes)

1:10-17 Divisions in the Church

Supporting evidence for the beginning of a new unit or sub-unit at 1:10 includes the connective δὲ (*now*—NonNarr §8.2), the vocative ἀδελφοί (*brothers*—§8.9) and the orienter Παρακαλῶ ὑμᾶς (*I exhort you*—§8.10).

Δὲ indicates that the material that follows builds on 4-9 and makes a new point (‘Paul passes from thanksgiving to rebuke’—Godet p. 61) (DFNTG §7.1).

The hortatory thesis of 10 is followed by supportive material, so ‘has **deductive** style’ (NonNarr §2.4).

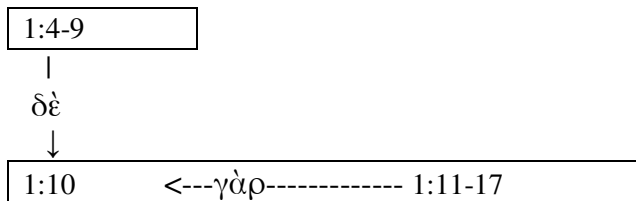

1:10a *Now I exhort you, brothers, by the name of our Lord Jesus Christ* (Παρακαλῶ δὲ ὑμᾶς, ἀδελφοί, διὰ τοῦ ὀνόματος τοῦ κυρίου ἡμῶν Ἰησοῦ Χριστοῦ).

The exhortations of 10 are presented with the orienter παρακαλῶ *I exhort (you)* followed by ἵνα *that* and subjunctive forms of the verb in the imperfective (‘present’), as they are things that the Corinthians are to keep on doing or not doing. They are very potent, because they are given *by the name* (‘authority’—TEV) *of our Lord Jesus Christ* (NonNarr §§7.2.1).

The non-initial position of the vocative ἀδελφοί (*brothers*) may identify what follows as ‘an important new idea’ (Ellingworth & Nida 1976, commenting on 1 Th. 2:1). It appears to be a rhetorical, slowing-down device to give prominence to what follows (NonNarr §7.7).⁵

The positive – negative – positive paraphrase of the underlying thesis in 10a-c also gives prominence to the exhortations of this verse (§7.7.2). This order of propositions, involving an *inclusio* structure (§4.1), should not be a problem in OV languages; it may be a problem in some VO languages that prefer to finish with a positive proposition (see *TrNotes*).

1:10b *that all of you say the same thing* (ἵνα τὸ αὐτὸ λέγητε πάντες). The DFE τὸ αὐτὸ (*the same thing*) is preposed to give it extra prominence (perhaps because it contrasts with reality!).

1:10c *and that there be no divisions among you* (καὶ μὴ ἦ ἐν ὑμῖν σχίσματα). Καὶ associates closely related propositions (NonNarr §3.1.2). In the light of 10b (*that all of you be in agreement*), 10c may well be a **counterpoint** to set off 10d to advantage by contrast (§3.3).

1:10d *but that you be united in the same mind and the same purpose* (ἦτε δὲ κατηρτισμένοι ἐν τῷ αὐτῷ νοῦ καὶ ἐν τῇ αὐτῇ γνώμῃ). ‘When δέ is used, the characteristic or proposition associated with δέ is more in focus; the negative proposition is usually discarded or replaced by the positive one’—

⁵ However, vocatives consistently follow any orienter or point of departure that occurs in the same sentence in 1 Corinthians.

DFNTG §7.1 p. 114. If you use a countering connective in your translation, it should imply that the new proposition progresses from or is more important than the preceding one (see NonNarr §3.2).

1:11 *For* (γάρ). Following the hortatory thesis of 10, γάρ introduces strengthening material that extends over at least 11-17 (Hoopert pp. 238-41; see the *inclusio* between 11-12 and 3:3-4). Γάρ is the **default** strengthening connective; it does NOT indicate a more specific logical relation (NonNarr §3.5.3).

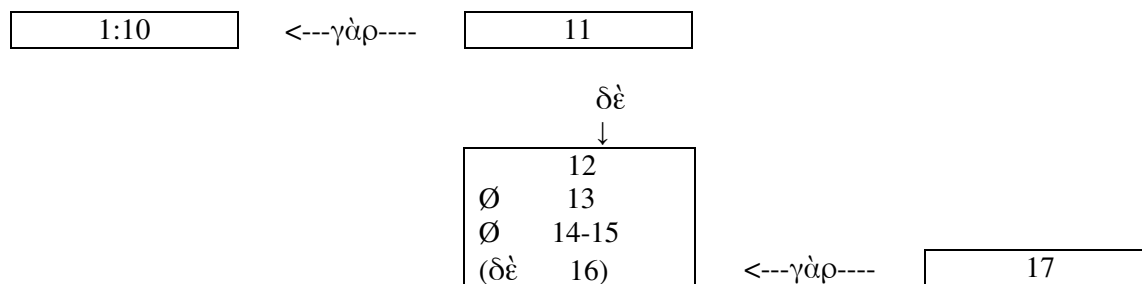

1:11a *it has been reported to me about you, my brothers, by Chloe's people* (ἐδηλώθη μοι περὶ ὑμῶν, ἀδελφοί μου, ὑπὸ τῶν Χλόης). The non-initial position of the vocative ἀδελφοί (*brothers*) may give prominence to what follows, especially the expository thesis of 11b that *there are contentions among you* (NonNarr §§7.7 & 8.9).

1:11b *that there are contentions among you* (ὅτι ἔριδες ἐν ὑμῖν εἰσιν). The proposition has presentational articulation; it presents or introduces a new entity (*contentions*) into the text (NonNarr §2.1).

The DFE ἔριδες (*contentions*) is proposed to give it extra (emphatic) prominence. It is normal for a pronominal constituent (in this case, ἐν ὑμῖν *among you*) to also precede the verb when a focal constituent is proposed for emphasis (*DFNTG* §3.7 p. 39).

1:12a *Now I say/mean this* (λέγω δὲ τοῦτο). Δὲ indicates progression in Paul's reasoning (*DFNTG* §7.1). In this instance, it introduces the next part of the supportive material that strengthens the hortatory thesis of 10.

Most commentators consider the proximal demonstrative τοῦτο (*this*) to be used **cataphorically**, pointing forward to and giving focal prominence to the material introduced by ὅτι *that, because* (12b).

1:12b *that each of you says* (ὅτι ἕκαστος ὑμῶν λέγει). The connective ὅτι shows that what follows interprets something that has already been said or implied (NonNarr §3.5.3). Here, it makes explicit what cataphoric τοῦτο (*this*) was pointing forward to.

The pre-verbal subject signals a switch of topic from *contentions* (11b) or *I* (12a).

1:12c *"I [on the one hand] belong to Paul"* (Ἐγὼ μὲν εἰμι Παύλου). The pre-verbal subject pronoun Ἐγὼ centres the attention on *I*, in contrast to others (also in 12d-f): 'As for me, I follow Paul' (*TrNotes*).⁶

The connective μὲν (*on the one hand*) is 'prospective' (*DFNTG* §10.1 p. 170); it anticipates or at least implies a corresponding sentence or sentences containing δὲ (which, in such a context, is often translated 'on the other hand'). Μὲν often backgrounds the sentence concerned with respect to what follows (*ibid.*)—in this case, 12d-f.

1:12d-f or *"I to Apollos," or "I to Cephas," or "I to Christ"* (Ἐγὼ δὲ Ἀπολλῶ, Ἐγὼ δὲ Κηφᾶ, Ἐγὼ δὲ Χριστοῦ).

1:13a *Has Christ been divided?* (μεμέρισται ὁ Χριστός;). The absence of a connective (asyndeton) is consistent with 13 being an **evaluation** of 12 (*DFNTG* §7.2 p. 119).

⁶ This is what *TrNotes* means by saying that the pronoun *I* is 'emphatic.'

The subject follows the verb as there is topic continuity, with attention still on *you* and the *divisions among you* (NonNarr §4.3.2). Nevertheless, the article shows that *Christ* is the propositional topic and the verb is focal.

The rhetorical questions of 13a-c give prominence to their underlying assertion ('A rhetorical question is one that is asked ... to give more emphasis or impact'—*UBS* p. 19). For example, *Has Christ been divided?* is more prominent than the equivalent negative assertion *Christ has not been divided* (NonNarr §7.7.4). (Also in 1:13b-c.)

1:13b *Was Paul crucified for you?* (μὴ Παῦλος ἐσταυρώθη ὑπὲρ ὑμῶν). A proposition with an identificational structure. The presupposition is a proposition that, except for one element, is assumed to be known ('[someone] was crucified for you'). The focus is the element that was lacking in the presupposed proposition (who the *someone* was—or wasn't, in this case) (NonNarr §2.1).

The focal subject Παῦλος (*Paul*) is preposed, following μὴ, to give it extra (emphatic) prominence. The omission of the article adds to the prominence (NonNarr §6.1.3).

1:13c *Or were you baptized in the name of Paul?* (ἢ εἰς τὸ ὄνομα Παύλου ἐβαπτίσθητε;). The presupposition is that they were baptised in someone's name. The focus is who that someone was. This focal constituent εἰς τὸ ὄνομα Παύλου (*in the name of Paul*) is preposed to give it extra (emphatic) prominence.

1:14a *I thank God* (εὐχαριστῶ [τῷ θεῷ]). As in 13a, the absence of a connective (asyndeton) is consistent with 14 being an evaluation of the assertion underlying 13c.

1:14b *that I baptized none of you except Crispus and Gaius* (ὅτι οὐδένα ὑμῶν ἐβάπτισα εἰ μὴ Κρίσπον καὶ Γάϊον). The negated constituent οὐδένα ὑμῶν (*none of you*) is brought into focus (*DFNTG* §4.1 p. 49) before the focus switches to the exceptions.

1:15a *so that no one can say* (ἵνα μὴ τις εἴπῃ). The subject is preposed, following the negative particle μὴ, to give it extra prominence (*ibid.*).

1:15b *that you were baptized in my name* (ὅτι εἰς τὸ ἐμὸν ὄνομα ἐβαπτίσθητε). The focal constituent εἰς τὸ ἐμὸν ὄνομα (*in my name*) is preposed to give it extra prominence. In addition, the 'emphatic' pronominal ἐμὸν (*my*) is preposed within this constituent.

1:16a *I did baptize also the household of Stephanas* (ἐβάπτισα δὲ καὶ τὸν Στεφανᾶ οἶκον). It is normal to use δὲ to introduce 'parenthetical' material which presents something 'distinctive' (*DFNTG* §5.4.1 p. 90).

Καὶ (*also*) adds a further object of *baptize* (*DFNTG* §6.3).

1:16b-c *beyond that, I do not know whether I baptized anyone else* (λοιπὸν οὐκ οἶδα εἴ τινα ἄλλον ἐβάπτισα). The additive λοιπὸν (*beyond that*) is used to add any **others** (the root meaning of the word).

The focal constituent τινα ἄλλον (*anyone else*) is preposed to give it extra (quasi-contrastive) prominence.

1:17a *For Christ did not send me to baptize* (οὐ γὰρ ἀπέστειλέν με Χριστὸς βαπτίζειν). The default strengthening connective γὰρ (*for*) introduces supportive material that gives a reason for part or all of 14-16 (see Trail p. 43, options 1-2).⁷

'When a clause negated by οὐ or μὴ is followed by the conjunction ἀλλά, then what is negated is often just the constituent that corresponds to the one introduced by ἀλλά' (*DFNTG* §4.1 p. 48). In this instance, what is negated is *to baptize*, not *sent me to baptize*.

⁷ The third option mentioned by Trail ('It serves as a transition to a new section'—*ibid.*) is NOT a description of the function of γὰρ.

The subject (Χριστὸς *Christ*) follows the verb because Paul continues to be concerned with the peripheral nature of him baptising people. In other words, there is topic continuity and attention does not switch to Christ (NonNarr §4.3.2).⁸

1:17b *but to proclaim the gospel* (ἀλλὰ εὐαγγελίζεσθαι). When the first proposition of a pair is **negative** and the second **positive**, then the DEFAULT way of conjoining them is with ἀλλά (NonNarr §3.2.2).

1:17c *not with eloquent wisdom* (οὐκ ἐν σοφίᾳ λόγου). This addition to the sentence introduces a new expository thesis ('great truth'—Lenski p. 49), which is followed by a 'long elaboration' in 1:18-2:16 (Fee 1987:64).

1:17d *so that the cross of Christ might not be emptied of its power* (ἵνα μὴ κενωθῆ ὁ σταυρὸς τοῦ Χριστοῦ). The subject probably follows the verb as there is topic continuity, with attention still on Paul baptising (see comment on 17a). Attention only switches to *the message about the Cross* in 18 (NonNarr §4.3.2).

1:18-31 or 2:5 Christ the Wisdom and Power of God

Supporting evidence for the beginning of a new sub-unit at 1:18 includes the pre-verbal subject Ὁ λόγος ὁ τοῦ σταυροῦ (*the message about the cross*—NonNarr §8.2) and the shift of tense from past to present (§8.11). However, the connective used is γὰρ, which indicates that the following material supports and strengthens preceding material (in this case, part or all of 17—see Trail p. 47).

The following is a flow chart for 1:17-25.

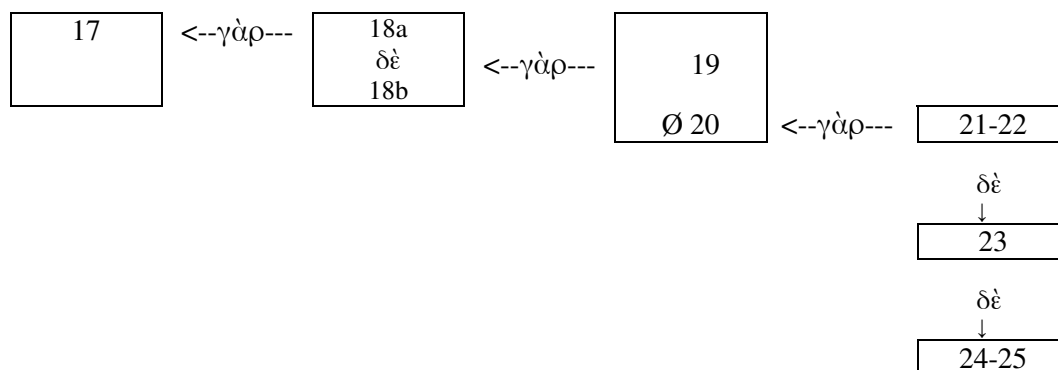

1:18a *the message about the cross is foolishness on the one hand to those who are perishing* (Ὁ λόγος ὁ τοῦ σταυροῦ τοῖς μὲν ἀπολλυμένοις μωρία ἐστίν). The pre-verbal subject signals a switch of attention from *I* (Paul) baptising (14-17). This is followed by a second constituent preposed to provide a point of departure for the communication (NonNarr §4.3): τοῖς ἀπολλυμένοις (*to those who are perishing*).

The focal constituent μωρία (*foolishness*) is preposed to give it extra prominence (anticipating a contrast with *the power of God* in 18b).⁹ This is confirmed by the presence of μὲν (*on the one hand*—see the comment on 12c), which anticipates the corresponding sentence containing δὲ (*on the other hand*—18b). The presence of μὲν may also background 18a with respect to 18b, in which case 18a could be a counterpoint to set off 18b to advantage by contrast (§3.3).

1:18b *but to us who are being saved, on the other hand, it is the power of God* (τοῖς δὲ σωζομένοις ἡμῶν δύναμις θεοῦ ἐστίν). The preposing of τοῖς σωζομένοις ἡμῶν (*to us who are being saved*) signals a switch of referential point of departure from *to those who are perishing* (18a).

⁸ When Χριστὸς (*Christ*) stands alone as subject in 1 Corinthians, it never takes the article.

⁹ I see no evidence that 'the word translated *is* has rather more emphasis in Greek than in English' (UBS p. 24). Rather, it is needed to show that μωρία has been preposed for extra prominence.

The focal constituent δύναμις θεοῦ (*the power of God*) is preposed to give it extra (contrastive) prominence (NonNarr §5.2.1). The omission of the article adds to the prominence (NonNarr §6.1.3).

1:19a *For it is written* (γέγραπται γάρ). Γάρ (*for*) introduces supportive material that strengthens 18 (see Trail p. 49). ‘Paul seems to mean “What I have just said is confirmed by scripture when it says...”’ (UBS p. 25).

1:19b-c. Note the chiasmic structure in this quote from the LXX of Is. 29:14 (V O – O V). In the same passage in Hebrew, the verbs are focal.

1:19b *I will destroy the wisdom of the wise* (Ἀπολωῶ τὴν σοφίαν τῶν σοφῶν).

1:19c *and the discernment of the discerning I will thwart* (καὶ τὴν σύνεσιν τῶν συνετῶν ἀθετήσω). If the verb is focal (see above), then the order of constituents conforms to the Principle of Natural Information Flow (NonNarr §4.4).

1:20. Although TEV inserts the connectives ‘so then’ ‘to indicate that Paul is about to draw a conclusion from the Old Testament verse that he has just quoted’ (UBS p. 26), there is no connective in the Greek. Hoopert (pp. 242-45) views 20ff as an **amplification** of 18-19 (see also Fee’s comment, ‘these questions, rather than beginning the argument or explanation proper, continue the point of the quotation in v. 19’—p. 70),¹⁰ and such a relation is consistent with asyndeton.

No connective links 20a-c, either, as the propositions ‘are of equal importance and parallel to each other’ (DFNTG §7.2 p. 120).

Finally, the absence of a connective in 20d is consistent with a shift from scene-setting material (20a-c) to ‘the final rhetorical question’ with which ‘Paul sets his own argument in motion’ (Fee p. 71).

1:20a-c *Where is one who is wise? Where is the scribe? Where is the debater of this age?* (ποῦ σοφός; ποῦ γραμματεὺς; ποῦ συζητητῆς τοῦ αἰῶνος τούτου;). A set of rhetorical questions with parallel progression gives further prominence to the underlying assertion (NonNarr §7.7.4).¹¹

The proximal demonstrative τούτου (*of this*) is used exophorically, i.e. for a referent found in the external world (NonNarr §6.1—also in 2:6 [bis], 2:8, 3:18 and 3:19).

1:20d *Has not God made foolish the wisdom of the world?* (οὐχὶ ἐμώρανεν ὁ θεὸς τὴν σοφίαν τοῦ κόσμου;). Using a rhetorical question gives prominence to its underlying assertion (NonNarr §7.7.4).

The order of constituents is default. The subject follows the verb as there is topic continuity, with attention still on wisdom and foolishness (also in 21a and 21b) (NonNarr §4.3.2).

1:21a *For since, in the wisdom of God, the world through wisdom did not know God* (ἐπειδὴ γὰρ ἐν τῇ σοφίᾳ τοῦ θεοῦ οὐκ ἔγνω ὁ κόσμος διὰ τῆς σοφίας τὸν θεόν). Γάρ (*for*) introduces supportive material that strengthens the expository thesis underlying 20d (NonNarr §3.5.3).

ἐπειδὴ ἐν τῇ σοφίᾳ τοῦ θεοῦ οὐκ ἔγνω ὁ κόσμος διὰ τῆς σοφίας τὸν θεόν (*Since, in the wisdom of God, the world did not know God through wisdom*) is a pre-nuclear reason clause that provides a situational point of departure for 21b-c. Since this situation is more or less implied in 19-20, it could perhaps be viewed as a point of departure by renewal (DFNTG §2.3).

ἐν τῇ σοφίᾳ τοῦ θεοῦ (*in the wisdom of God*) is a situational point of departure for the rest of the subordinate clause (see Trail p. 55 on the relationship indicated by ἐν). It contrasts with *the wisdom of the world* (20d).

The subject (ὁ κόσμος *the world*) is not preposed, as attention remains on wisdom and foolishness (see comment on 20d), rather than switching to *the world* (NonNarr §4.3.2).

¹⁰ ‘The meaning is ... that where the cross is preached human wisdom can no longer stand’ (Grosheide 1953:45).

¹¹ For similar rhetorical questions with *where*, see Isa. 33:18 and 1 Cor. 15:55.

The object (τὸν θεόν *God*) is postposed to give it extra prominence, presumably to bring out the irony that the world's wisdom did not lead it to know God.

1:21b *God decided* (εὐδόκησεν ὁ θεός). See comment on 20d.

1:21c *to save those who believe through the foolishness of the proclamation* (διὰ τῆς μωρίας τοῦ κηρύγματος σῶσαι τοὺς πιστεύοντας). The DFE διὰ τῆς μωρίας τοῦ κηρύγματος (*through the foolishness of the proclamation*) is preposed to give it extra (contrastive and emphatic) prominence.

1:22a-b *Since Jews demand signs and Greeks desire wisdom* (ἐπειδὴ καὶ Ἰουδαῖοι σημεῖα αἰτοῦσιν καὶ Ἕλληνες σοφίαν ζητοῦσιν). Translations such as NRSV that render ἐπειδὴ as 'for' hide the fact that it is a **subordinating** conjunction (it co-occurs with γὰρ in 21a). As Trail (p. 58) indicates, these clauses can be subordinated either to what follows (23—options 3 & 4) or to what precedes (21b-c or 20—options 1 & 2).

If these clauses are subordinated to what **follows**, then they are pre-nuclear and signal a switch of situation from that of 21 (*DFNTG* §2.2).¹² The problem with this analysis is that δὲ then occurs between the subordinate clauses of 22a and the main clause of 23a—unless the pre-nuclear reason clauses include 23a, which seems to be the position of *ICC* (p. 21) when it paraphrases 22-23a: 'Since—while Jews and Gentiles alike demand something which suits their unsympathetic limitations—we, on the other hand, preach...'.¹³

If these clauses are subordinated to what **precedes** (or to an implied main clause such as 'God's way seems foolish to the Jews'), then Paul uses ἐπειδὴ 'here because he is about to explain why the Jews and the Greeks thought that the Gospel was foolish' (*TrNotes*).

1:22a *Since Jews demand signs* (ἐπειδὴ καὶ Ἰουδαῖοι σημεῖα αἰτοῦσιν). Καὶ here could be a marker of confirmation (*DFNTG* §6.2 p. 101) glossed 'indeed' (Trail's second option—p. 59). However, the presence of a second καὶ in 22b makes me think that it is the first part of a *both ... and* pair (Trail's first option—p. 58; see Lenski p. 64). The *UBS* comment on 24 gives the motivation for this pairing: 'The context seems to show that the important contrast is between Jews and Gentiles on the one hand, and Christian preachers on the other' (pp. 29-30).

The subject precedes the verb to signal a switch of topic from *God* (21). The focal object σημεῖα *signs* is preposed for contrastive prominence or as a foil to provide a contrast with *Christ crucified* (23a) (see *NonNarr* §5.2.1).

1:22b *and Greeks desire wisdom* (καὶ Ἕλληνες σοφίαν ζητοῦσιν). Καὶ associates 22a and 22b together, over against the main point of 23 (*NonNarr* §3.1.2). The subject precedes the verb to signal a switch of topic from *Jews* (22). Again, the focal object σοφίαν *wisdom* is preposed for contrastive prominence or to provide a contrast with *Christ crucified* (23a).

1:23a *but we proclaim Christ crucified* (ἡμεῖς δὲ κηρύσσομεν Χριστὸν ἑσταυρωμένον). Δὲ indicates progression in Paul's reasoning; in this instance, from comments about *Jews* and *Greeks* to one about *we* (exclusive). The pre-verbal subject pronoun ἡμεῖς (*we*) also centres the attention on 'us', in contrast to the groups of 22 ('As for us'—TEV).

The lack of an article with Χριστὸν (*Christ*) gives extra (contrastive) prominence to the DFE *Christ crucified*.

1:23b *to Jews a stumbling block* (Ἰουδαίοις μὲν σκάνδαλον). See 1:12c on μὲν ... δὲ ... δὲ. Although there is no verb, Ἰουδαίοις (*to Jews*) should probably be treated as a referential point of departure for the rest of the proposition (see *TrNotes*).

¹² Lenski (p. 64) describes these 'since' clauses as 'a parallel to the previous sentence, but a parallel that is elaborated in fuller detail'.

1:23c *and to Gentiles foolishness* (ἔθνεσιν δὲ μωρίαν). As in 23b, ἔθνεσιν (*to Gentiles*) should probably be treated as a referential point of departure for the rest of the proposition, signalling a switch of attention from *to Jews* (see *TrNotes*)—but NOT a contrastive switch (*UBS* p. 29; δὲ is translated *and*).

1:24a *but to those who are called, both Jews and Greeks* (αὐτοῖς δὲ τοῖς κλητοῖς, Ἰουδαίοις τε καὶ Ἑλλήσιν). Once again, this complex constituent should probably be treated as a referential point of departure for the rest of the proposition, marking a switch of attention from *to Gentiles*.

1:24b *Christ the power of God and the wisdom of God* (Χριστὸν θεοῦ δύναμιν καὶ θεοῦ σοφίαν). The genitive θεοῦ is preposed and the article omitted (twice) to give it extra (contrastive) prominence (NonNarr §§5.5, 6.1.3). In fact, the whole focal constituent lacks the article, and is thus given extra prominence.

1:25 *Because* (ὅτι). The interpretive use marker ὅτι introduces a reason or evidence for the last assertion (24). The associative conjunction καὶ shows that 25a and 25b together constitute the reason for 24.

There is chiasm between 24b and 25a-b (power – wisdom; foolishness/wiser – weakness/stronger).

1:25a *God's foolishness is wiser than human wisdom* (τὸ μωρὸν τοῦ θεοῦ σοφώτερον τῶν ἀνθρώπων ἐστίν). The subject is pre-verbal to signal a switch of topic from *we* (23) and *Christ* (24b).

The focal constituent σοφώτερον τῶν ἀνθρώπων (literally, *wiser than the men*) is preposed to give it extra (emphatic and/or contrastive) prominence.

1:25b *and God's weakness is stronger than human strength* (καὶ τὸ ἀσθενὲς τοῦ θεοῦ ἰσχυρότερον τῶν ἀνθρώπων). As in 25a, the subject is pre-verbal to signal a switch of topic from *God's weakness*.

The focal constituent ἰσχυρότερον τῶν ἀνθρώπων (literally, *stronger than the men*) is preposed to give it extra (emphatic and/or contrastive) prominence.

1:26. Supporting evidence for the beginning of a new sub-unit at 1:26 includes the vocative ἀδελφοί (*brothers*—NonNarr §8.9) and the orienter Βλέπετε (*consider*—§8.10). However, the connective used is γὰρ, which indicates that the following material supports and strengthens preceding material (in this case, 25). As *UBS* notes, ‘The links with verses 18–25 are close. The theme is still weakness and folly, contrasted with strength and wisdom’.

The following is a flow chart for 1:24-31.

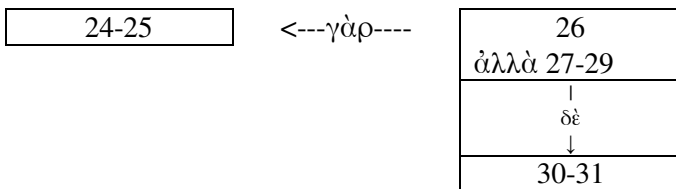

1:26a *consider your own call, brothers* (Βλέπετε τὴν κλῆσιν ὑμῶν, ἀδελφοί). Βλέπετε may be taken as indicative (‘you see’) or imperative (‘see, consider’). Either way, it appears to function as an **attention getter** (NonNarr §2.2.4).

The non-initial position of the vocative ἀδελφοί (*brothers*) may give prominence to what follows (26bff) (NonNarr §7.7).¹³

1:26b *that not many of you were wise by human standards* (ὅτι οὐ πολλοὶ σοφοὶ κατὰ σάρκα). The connective ὅτι interprets 26a by giving ‘the specifics of the word “calling”’ (Trail p. 65, referring to *ICC* p. 25).

1:26c-d *not many were powerful, not many were of noble birth* (οὐ πολλοὶ δυνατοί, οὐ πολλοὶ εὐγενεῖς).

¹³ Concerning the comment, ‘In your translation you should put it where it sounds natural in your language’ (*TrNotes*), see 1:10a.

1:27-28 *But* (ἀλλὰ). The **default** way, following negative propositions, of conjoining positive ones (NonNarr §3.2.2; it is misleading to call ἀλλὰ ‘a strong **but**’—*UBS* p. 32). The associative conjunction καὶ shows that the domain of ἀλλὰ extends over more than the one sentence.

Like 26b-d, 27-28 exhibit **parallel progression** (NonNarr §4.1), which is often used to give prominence to the underlying thesis. Parallel progression is often combined with **negative - ἀλλὰ - positive paraphrase**, as in 26-28, again with the purpose of giving prominence to the underlying thesis (NonNarr §7.7.2).

1:27a-b *God chose what is foolish in the world to shame the wise* (τὰ μωρὰ τοῦ κόσμου ἐξελέξατο ὁ θεός ἵνα κατασχύνῃ τοὺς σοφοὺς). The subject follows the verb in 27a, 27c and 28a because there is topic continuity with 26, as Paul has already stated that, among those called by God, there are not many wise men, not many powerful, not many well-born (NonNarr §4.3.2). The repetition of ἐξελέξατο ὁ θεός (*God chose*) reinforces the parallel progression; I’m not convinced that these words are ‘emphasized’ (see Trail p. 67) in any other sense.

In contrast, the focal constituents of 27a, 27c and 28 (e.g. τὰ μωρὰ τοῦ κόσμου *what is foolish in the world*) are preposed for extra (contrastive) prominence (NonNarr §5.2.1—see Godet p. 112).

1:27c-d *And God chose what is weak in the world to shame the strong* (καὶ τὰ ἀσθενῆ τοῦ κόσμου ἐξελέξατο ὁ θεός ἵνα κατασχύνῃ τὰ ἰσχυρά). See comments on 27a-b.

1:28a *And God chose what is low and despised in the world* (καὶ τὰ ἀγενῆ τοῦ κόσμου καὶ τὰ ἐξουθενημένα ἐξελέξατο ὁ θεός). See comments on 27a-b.

1:28b [*even*] *the things that are not* ([καὶ] τὰ μὴ ὄντα).

1:28c *to reduce to nothing the things that are* (ἵνα τὰ ὄντα καταργήσῃ). Marked but ambiguous constituent order. Since the objects of 27-28b were preposed to give them extra prominence, I consider τὰ ὄντα (*the things that are*) to be preposed for extra (contrastive) prominence, too.

1:29 *so that all flesh might not boast before God* (ὅπως μὴ καυχῆσθαι πᾶσα σὰρξ ἐνώπιον τοῦ θεοῦ). ὅπως is typically used to introduce a **desired result** (here, the ‘ultimate/final purpose’ of 27-28—see Trail p. 72).

The subject (πᾶσα σὰρξ *all flesh*) follows the verb as there is topic continuity with 28c (NonNarr §4.3.2).

1:30a *And/Now/But it is because of him that you are in Christ Jesus* (ἐξ αὐτοῦ δὲ ὑμεῖς ἐστε ἐν Χριστῷ Ἰησοῦ). Δὲ indicates progression in Paul’s reasoning. Hoopert (p. 247) links this assertion to the summary statement of 28b (*the things that are not*). This interpretation corresponds to Trail’s Option 2 (δὲ ‘indicates transition’—p. 73). Option 1 (δὲ ‘indicates contrast’) is problematic because, were the contrast to be ‘between the words ὑμεῖς “you” and the “worldly wise” of the preceding context’ (ibid.), then ὑμεῖς would have begun the sentence (see further below).

The focal constituent ἐξ αὐτοῦ *from him* is preposed for extra prominence (‘It is of him that...’—ibid. Option 1). Consequently, the pronominal constituent ὑμεῖς (*you*) also precedes the verb (*DFNTG* §3.7 p. 39). Because ὑμεῖς does not begin the sentence, its meaning can NOT be ‘As for you’ (Trail’s Option 2). The pronoun does give **THEMATIC** prominence to *you*, though (represented in oral English by secondary accent on YOU—see *NARR* §4.9 for discussion of cleft sentences in which both parts are accented): *And it is because of Him that YOU are in Christ Jesus*.

1:30b *who became for us wisdom from God* (ὃς ἐγενήθη σοφία ἡμῖν ἀπὸ θεοῦ). A non-restrictive relative clause, used in connection with sequential progression, in which a constituent of the comment of one proposition (here, *Christ Jesus*) becomes topical in the next (NonNarr §4.1). It may also be ‘continuative’, with 30a backgrounded with respect to 30b-c.

The order of constituents is marked (default order would have placed the pronoun ἡμῖν (*for us*) immediately after the verb—*DFNTG* §3.1 p. 29). The marked order can be explained if the words ἀπὸ θεοῦ (*from God*) are connected with σοφία (*wisdom*) (Trail’s Option 2—p. 75). σοφία ... ἀπὸ θεοῦ is then a constituent that is discontinuous ‘due to its parts being unequally relevant’ (*DFNTG* §4.4.2 p. 58). The lack of the article in ἀπὸ θεοῦ indicates that *from God* is the more prominent part of the constituent (*wisdom from Góð*).¹⁴

1:30c *also/both righteousness and sanctification and redemption* (δικαιοσύνη τε καὶ ἁγιασμὸς καὶ ἀπολύτρωσις). IF Trail’s Option 2 (p. 76) is followed, then ‘in addition’ or ‘furthermore’ would be a good translation of additive τε (see *DFNTG* §6.3 pp. 109f).

1:31. If you are following *TrNotes*, please note that, in Greek, this verse does NOT begin with the ‘connecting word *therefore*’! 31 supports the expository thesis of 30b-c by presenting its purpose. It should NOT be introduced in a way that makes it more important than 30.

1:31a *in order that, as it is written* (ἵνα καθὼς γέγραπται). As it stands, καθὼς γέγραπται (*as it is written*) is a point of departure for 31b, marking a switch of situation from Paul’s argument itself to a supporting Scripture (see Trail pp. 78-79 Option 1).

1:31b “*Let the one who boasts, boast in the Lord*” (Ὁ καυχώμενος ἐν κυρίῳ καυχάσθω). The subject is not pre-verbal in Jer. 9:24. It precedes the verb here to signal a change of topic from *Christ Jesus* (30).

This reported 3rd person exhortation is an imperfective (‘present’) imperative, as it is to be obeyed on an ongoing basis (NonNarr §7.2.1-2).

The focal constituent ἐν κυρίῳ (*in the Lord*) is preposed to give it extra (contrastive) prominence. The lack of the article increases the prominence.

(2:1-5 Proclaiming Christ Crucified)

Supporting evidence for the beginning of a new sub-unit at 2:1 includes the pre-verbal subject pronoun ἐγὼ (*I*) (NonNarr §§8.2 & 8.8) and the vocative ἀδελφοί (*brothers*—§8.9). However, the connective καὶ indicates that the theme is a continuation of Paul’s ‘defence of his mode of preaching’ (Hodge 1857(1980):29). Fee’s title (p. 66), ‘The Gospel—a Contradiction to Wisdom’ encompasses 1:18-2:5 (see also *UBS* p. 37, which also relates it to 1:14-17).

The following is a flow chart for 1:17-2:5 (see 1:18 for the flow chart for 1:17-20).

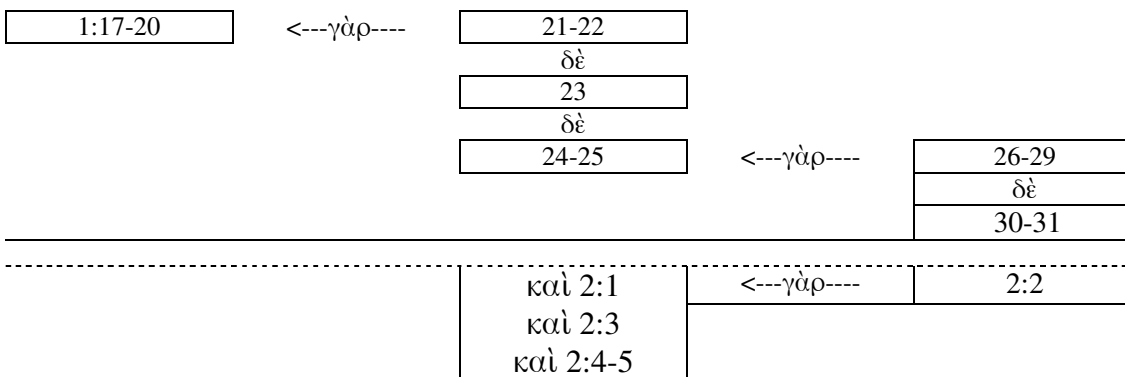

2:1a *And when I came to you, brothers* (Κἀγὼ ἐλθὼν πρὸς ὑμᾶς, ἀδελφοί). A pre-nuclear participial clause, backgrounded with respect to 1b (*DFNTG* §11.1.2).

¹⁴ *UBS* is wrong in suggesting that *our* or *wisdom* is emphasised.

When a focal constituent is discontinuous ‘due to its parts being unequally relevant’, *DFNTG* (ibid.) only allows for the first part to be more prominent, with the second part supportive. Further research, however, indicates that, in some contexts, it is the second part that is more prominent.

The pre-verbal subject pronoun (*I*) signals a switch of attention from the topics of 1:24-31 to Paul himself: ‘And I, for my part’ (*TrNotes*).

The non-initial position of the vocative ἀδελφοί (*brothers*) may again give prominence to what follows (1b-c) (NonNarr §7.7).

2:1b-c *I came not with lofty words or wisdom proclaiming the testimony of God* (ἦλθον οὐ καθ’ ὑπεροχὴν λόγου ἢ σοφίας καταγγέλλων ὑμῖν τὸ μαπτ(ριον τοῦ θεοῦ).¹⁵ Οὐ καθ’ ὑπεροχὴν λόγου ἢ σοφίας (*not with lofty words or wisdom*) can be connected with either (a) the main verb ἦλθον (*I came*) or (b) the post-nuclear participial clause καταγγέλλων ὑμῖν τὸ μαπτ(ριον τοῦ θεοῦ) (*proclaiming the testimony of God*) (see Trail p. 81).

- (a) If it is connected with ἦλθον, then the negative particle οὐ follows the verb, which is uncommon, but not unlikely in this context, given that ἦλθον is repeated from 1a.
- (b) If it is connected with καταγγέλλων ὑμῖν τὸ μυστήριον τοῦ θεοῦ, then the focal constituent καθ’ ὑπεροχὴν λόγου ἢ σοφίας (*with lofty words or wisdom*) has been preposed, following the negative particle οὐ, to give it extra (emphatic) prominence.

2:2a-b *For I decided to know nothing among you except Jesus Christ* (οὐ γὰρ ἔκρινά τι εἰδέναι ἐν ὑμῖν μὴ Ἰησοῦν Χριστόν). Γὰρ (*for*) ‘shows that the function of this verse is to explain in greater detail what has been said in verse 1’ (*UBS* p. 39).

What is negated is τι (*anything*—see comment on 1:17a). This focal constituent is preposed (before εἰδέναι *to know*) to give it extra prominence (as a foil, with the rhetorical effect of setting *except Jesus Christ* off to advantage by contrast (NonNarr §5.2.1).

2:2c *and this one crucified* (καὶ τοῦτον ἐσταυρωμένον). The natural centre of attention in an autobiographical passage is the writer, so Paul uses the proximal demonstrative οὗτος to switch attention temporarily to *Jesus Christ* (NonNarr §6.1).

2:3 *And I came to you in weakness and in fear and in much trembling* (κἀγὼ ἐν ἀσθενείᾳ καὶ ἐν φόβῳ καὶ ἐν τρόμῳ πολλῷ ἐγενόμην πρὸς ὑμᾶς). The connective καὶ (*and*) associates what follows with 1-2.

The repetition of the subject pronoun (*I*) prior to the verb (a ‘point of departure involving renewal’—*DFNTG* §2.3 pp. 12-13) indicates that what follows is a **different** comment about the same topic.

The whole of the focal complement *in weakness and in fear and in much trembling* (ἐν ἀσθενείᾳ καὶ ἐν φόβῳ καὶ ἐν τρόμῳ πολλῷ) is preposed to give it extra (emphatic) prominence. It is more normal in Greek for the first part of a co-ordinative focal constituent to begin a proposition and be separated from the remainder by the verb or another constituent (*DFNTG* §4.4.1 pp. 57f). Failure to do so, and the repetition of the preposition ἐν (*in*), presumably adds to the emphasis given to this constituent.

2:4a *And my speech and my proclamation were not with plausible words of wisdom* (καὶ ὁ λόγος μου καὶ τὸ κήρυγμά μου οὐκ ἐν πειθοῖ[ς] σοφίας [λόγοις]). The connective καὶ (*and*) again associates what follows with 1-3.

The pre-verbal subject ὁ λόγος μου καὶ τὸ κήρυγμά μου (*my speech and my proclamation*) signals a switch of topic from *I* (1-3).

ἐν πειθοῖ[ς] σοφίας [λόγοις] (*with plausible words of wisdom*). If λόγοις is retained, then the genitive σοφίας (*of wisdom*) is preposed within this focal constituent to give it extra prominence (as foil to set off *with a demonstration of the Spirit and of power* to advantage by contrast— NonNarr §§5.5, 5.2.1).

¹⁵ I prefer the reading τὸ μαπτ(ριον (*the testimony*) (*UBS* 25th edition) to τὸ μυστήριον (*the mystery*) because of the article (*the testimony* was mentioned in 1:6, whereas there has been no previous reference to *mystery*).

2:4b *but with a demonstration of the Spirit and of power* (ἀλλ' ἐν ἀποδείξει πνεύματος καὶ δυνάμεως). Following a negative proposition, ἀλλὰ (*but*) is the default connective to introduce a positive proposition (NonNarr §3.2.2). (Also in 2:5b.)

This is the first reference to *the Spirit*, so no article is used (§6.1.3).

2:5a *so that your faith might rest not on human wisdom* (ἵνα ἡ πίστις ὑμῶν μὴ ᾖ ἐν σοφίᾳ ἀνθρώπων). The pre-verbal subject ἡ πίστις ὑμῶν (*your faith*) signals a switch of topic from *my speech and my proclamation*.

What is negated is *on human wisdom* (see comment on 1:17a). This clause is an implied exhortation not to let *your faith rest on human wisdom but on the power of God* (NonNarr §7.2.1).

2:5b *but on the power of God* (ἀλλ' ἐν δυνάμει θεοῦ). See 2:4b on ἀλλὰ (*but*).

The absence of an article with the focal constituent ἐν δυνάμει θεοῦ (*on the power of God*) gives it extra (contrastive) prominence.

2:6-2:16 or 3:23 God's Wisdom

Supporting evidence for the beginning of a new unit or sub-unit at 2:6 includes the point of departure Σοφίαν (*wisdom*— NonNarr §8.2), the connective δὲ (§8.3), and the shift of person and tense (from 1st singular to plural and from past to present—§8.11).

The following is a flow chart for 1:21-2:11 (see later for a flow chart for 2:10-16).

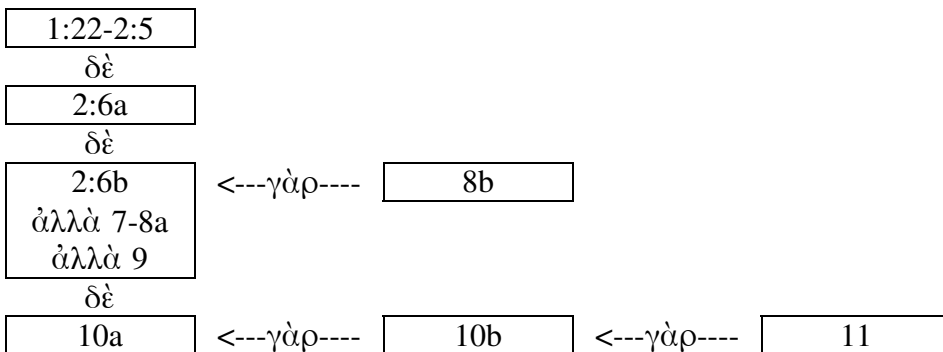

2:6a *Yet we do speak wisdom among the mature* (Σοφίαν δὲ λαλοῦμεν ἐν τοῖς τελείοις). Δὲ indicates progression in Paul's reasoning, as he builds on what he has written in previous verses.

As ICC's suggestion ('Now by wisdom...'—p. 36) indicates, σοφίαν (*wisdom*) is proposed to provide a point of departure for what follows, as well as signalling a switch of topic from previous verses (e.g. *your faith* in 5).

2:6b *though it is not a wisdom of this age or of the rulers of this age* (σοφίαν δὲ οὐ τοῦ αἰῶνος τούτου οὐδὲ τῶν ἀρχόντων τοῦ αἰῶνος τούτου). Δὲ again indicates progression in Paul's reasoning, as he moves from wisdom in general to the specific type of wisdom that he will define both negatively (6b) and positively (7a).

2:6c *the ones becoming nothing* (τῶν καταργουμένων). This clause functions like an attributive adjective and may be translated into English by a relative clause (see 1:2a for references). In this instance, though, the relative clause is **non**-restrictive (it does not define **which** rulers of this age Paul is writing about), which presents problems in many languages (NARR §10.3.4).

Although the participle καταργουμένων (*being reduced to nothing*—1:28c) is described as 'present' (as though it were marked for tense), in fact it has imperfective **aspect**.

2:7a *But we speak God's wisdom in a mystery the hidden* (ἀλλὰ λαλοῦμεν θεοῦ σοφίαν ἐν μυστηρίῳ τὴν ἀποκεκρυμμένην). As in 1:27-28, ἀλλὰ is not a 'strong **but**' (UBS p. 46), but the default way, following negative propositions, of conjoining positive ones (NonNarr §3.2.2).

θεοῦ σοφίαν (*God's wisdom*). The genitive θεοῦ is preposed within the focal constituent to give it extra (contrastive) prominence ('The word *God's* is emphatic'—*TrNotes*).¹⁶

Τὴν ἀποκεκρυμμένην (*the one having been hidden*) functions like an attributive adjective and may be translated into English by a relative clause. As in 6c, the relative clause is **non**-restrictive. If Trail's Option 2 (p. 94) is followed, then this constituent is in apposition to *God's wisdom*.

2:7b *which God decreed before the ages for our glory* (ἣν προώρισεν ὁ θεὸς πρὸ τῶν αἰώνων εἰς δόξαν ἡμῶν). A non-restrictive relative clause used in connection with sequential progression, in which a constituent of the comment of one proposition (here, *God's wisdom*) becomes topical in the next (NonNarr §4.1).

Attention is on *God's wisdom* (7a), rather than the post-verbal subject ὁ θεὸς *God*' (NonNarr §4.3.2).

The proposition has default constituent order, finishing with 'the more focal constituent' εἰς δόξαν ἡμῶν *for our glory* (DFNTG §3.4 p. 32)—see the further reference to *glory* in 8c.

2:8a *which none of the rulers of this age understood* (ἣν οὐδεὶς τῶν ἀρχόντων τοῦ αἰῶνος τούτου ἔγνωκεν). Another non-restrictive relative clause, either with the same topic (*God's wisdom*) or with the topic now *a hidden (wisdom)*.

The negated subject οὐδεὶς τῶν ἀρχόντων τοῦ αἰῶνος τούτου (*none of the rulers of this age*) is probably the DFE (DFNTG §4.1 p. 49), though it could be that the verb has been postposed to give it extra prominence (NonNarr §5.3).

2:8b *for if they had* (εἰ γὰρ ἔγνωσαν). Γὰρ (*for*) introduces supportive material that strengthens the assertion of 8a. 'Paul is explaining how we know that the rulers of this world did not understand God's plan' (*TrNotes*).

The pre-nuclear conditional clause signals a switch of situation from that of 8a (DFNTG §2.2).

2:8c *they would not have crucified the Lord of glory* (οὐκ ἂν τὸν κύριον τῆς δόξης ἐσταύρωσαν). The focal constituent τὸν κύριον τῆς δόξης (*the Lord of glory*) is preposed, following the negative particle οὐ, to give it extra prominence (DFNTG §4.1).

2:9a *But, as it is written* (ἀλλὰ καθὼς γέγραπται). I agree with *TrNotes* that the first option presented there 'fits the grammar better'. In other words, the contrast signalled by ἀλλὰ is between *if they had* [understood God's plan] (8b) and the implied proposition, 'But they didn't understand it'.¹⁷

As in 1:31a, καθὼς γέγραπται (*as it is written*) is a point of departure for the Scripture quotation of 9b.

2:9b-c. With reference to Trail's responses to the question, 'To what is this scripture quotation connected?' (p. 98), as it stands it 'is not grammatically connected to anything and stands as a unit in itself' (Option 3). Nevertheless, that does not stop it being 'the object of an implied 'we speak' from 2:7' (Option 1) or the **understood** object of *God revealed* (Option 2) as Paul develops his argument further in 10.

¹⁶ Edwards (1885(1979)) is wrong in saying that the emphasis in this verse is on 'we speak' (as cited by Trail p. 94).

¹⁷ The problem with the second interpretation (treating the OT quote in 2:9b-c as a parenthesis) is that the "'But" of verse 10' (δὲ) does not have the same function as ἀλλὰ. It is therefore wrong to say that it 'repeats the stronger **But** at the beginning of the present verse' (UBS p. 48).

2:9b *The things that eye did not see and ear did not hear and (that) did not enter into the heart of man* (Ἄ ὀφθαλμὸς οὐκ εἶδεν καὶ οὐκ ἤκουσεν καὶ ἐπὶ καρδίαν ἀνθρώπου οὐκ ἀνέβη). The negated verbs are focal, so have been postposed (*DFNTG* §4.1 p. 48).

2:9c *the things that God prepared for those who love him* (ἃ ἠτοίμασεν ὁ θεὸς τοῖς ἀγαπῶσιν αὐτόν). The relative pronoun ἃ *the things that* indicates that attention is on these things, not on ὁ θεὸς (*God*), which therefore follows the verb (also 10a) (see *NonNarr* §4.3.2).

The order of constituents is default. As *UBS* (p. 48) points out, ‘There is nothing in the text that corresponds to TEV’s “is the very thing.”’

2:10a *But God revealed [it] to us through the Spirit* (ἡμῖν δὲ ἀπεκάλυψεν ὁ θεὸς διὰ τοῦ πνεύματος). If the *UBS* preferred reading is followed, δὲ indicates progression in Paul’s reasoning, as he moves from what God prepared to what He has now revealed. If γὰρ (*for*) is read, then 10a supports 9 by giving a [r]eason why we can utter things hidden from eye, ear, and mind of man’ (*ICC* p. 43).

The DFE ἡμῖν (*to us*) is preposed to give it extra (contrastive) prominence (*ibid.*).

2:10b *for the Spirit searches all things* (τὸ γὰρ πνεῦμα πάντα ἐραυνᾷ). Γὰρ (*for*) introduces supportive material that strengthens the assertion of 10a. ‘Paul explains how the Spirit knows God’s plans and can reveal them’ (*TrNotes*).

The pre-verbal subject signals a switch of attention from what God has prepared for those who love him (9). This is an instance of sequential progression (*NonNarr* §4.1) from 10a (*NonNarr* §4.3.2).

The DFE πάντα (*all things*) is preposed to give it extra (emphatic) prominence.

2:10c *even the depths of God* (καὶ τὰ βάθη τοῦ θεοῦ). This constituent ‘is added to the non-contiguous constituent πάντα in order to confirm that the Spirit truly examines *all* things. The depths of God’ is judged to be the *least likely* member of the set of all things that the Spirit (or, more likely, Paul’s opponents) might be able to examine (*DFNTG* §6.2 p. 101).

2:11a *For who of men knows the things of a man except the spirit of the man that is in him?* (τίς γὰρ οἶδεν ἀνθρώπων τὰ τοῦ ἀνθρώπου εἰ μὴ τὸ πνεῦμα τοῦ ἀνθρώπου τὸ ἐν αὐτῷ;). Γὰρ (*for*) again indicates that what follows (in this case, the whole of 11) strengthens previous material. ‘Paul tells them this to show that only God’s Spirit can know what God is thinking about’ (*TrNotes*). *UBS* (p. 50) is misleading in saying that ‘this verse introduces a new thought’; the next step in the progression of Paul’s argument does not occur until 12 (see δὲ).

The introduction of a question that is then answered highlights the answer. By asking *who of men knows the things of a man?*, Paul highlights the following exception (*except the spirit of the man that is in him*) (*NonNarr* §7.7.4).

The question phrase itself, τίς ... ἀνθρώπων (*who of men*), is probably discontinuous because only the second part relates (by contrast) to what follows (see *DFNTG* §4.4.2 p. 58).

2:11b *In the same way also no one comprehends what is truly God's except the Spirit of God* (οὕτως καὶ τὰ τοῦ θεοῦ οὐδεὶς ἔγνωκεν εἰ μὴ τὸ πνεῦμα τοῦ θεοῦ). The preposed object καὶ τὰ τοῦ θεοῦ *also the things of God* is a referential point of departure that signals a switch from *the things of a man* in 11a (*DFNTG* §2.2).

As in 1:14b, the negated constituent οὐδεὶς (*no one*) is brought into focus (*DFNTG* §4.1 p. 49) before attention switches to the exceptions.

The following is a flow chart for 2:10-16.

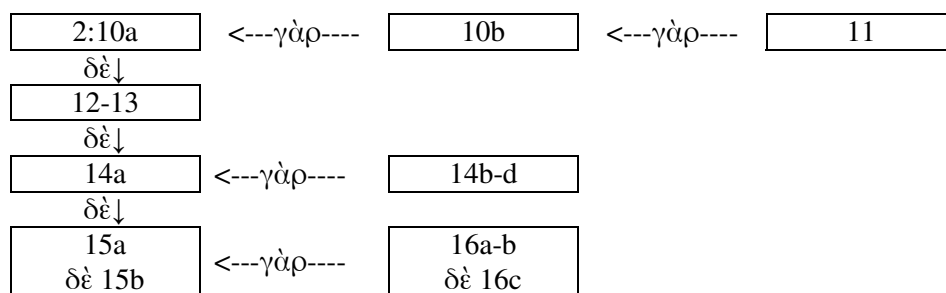

2:12a *Now we have received not the spirit of the world* (ἡμεῖς δὲ οὐ τὸ πνεῦμα τοῦ κόσμου ἐλάβομεν). As usual, δὲ indicates progression in Paul's reasoning, as he moves from God's revelation *to us through the Spirit* (10a) to the nature of the Spirit that we have received.¹⁸

The preverbal subject pronoun ἡμεῖς (*we*) signals a switch of topic (*we* is the subject throughout 12-13).

The focal constituent τὸ πνεῦμα τοῦ κόσμου (*the spirit of the world*) is preposed, following the negative particle οὐ, for extra prominence (as a foil to set off *the Spirit that is from God* to advantage by contrast (DFNTG §4.1, NonNarr §5.2.1).

2:12b *but the Spirit that is from God* (ἀλλὰ τὸ πνεῦμα τὸ ἐκ τοῦ θεοῦ). Following a negative proposition, ἀλλὰ (*but*) is the default connective to introduce a positive proposition (NonNarr §3.2.2).

2:12c *so that we may understand the things freely given to us by God* (ἵνα εἰδῶμεν τὰ ὑπὸ τοῦ θεοῦ χαρισθέντα ἡμῖν). (The order of constituents in the participial clause τὰ ὑπὸ τοῦ θεοῦ χαρισθέντα ἡμῖν (*literally, the things by the God having.been.freely.given to us*) conforms to the Principle of Natural Information Flow—NonNarr §4.4.)

2:13a *Which things we also speak not in words taught by human wisdom* (ἃ καὶ λαλοῦμεν οὐκ ἐν διδακτοῖς ἀνθρωπίνης σοφίας λόγοις). A non-restrictive relative clause used in connection with sequential progression, in which a constituent of the comment of one proposition (here, *the gifts bestowed on us by God*) becomes topical in the next (NonNarr §4.1). It may also be 'continuative', with 12c backgrounded with respect to 13b-c.

The additive καὶ (*also*) adds 'something new; [Paul] is saying that we not only understand God's gifts by means of his Spirit, but what is more, we speak about them' (UBS p. 51).

Within the focal prepositional phrase ἐν διδακτοῖς ἀνθρωπίνης σοφίας λόγοις (*in words taught by human wisdom*), the modifying participial clause διδακτοῖς ἀνθρωπίνης σοφίας (*taught by human wisdom*) is preposed to give it extra prominence (in anticipation of the contrast in 13b).

2:13b *but in ones taught by the Spirit* (ἀλλ' ἐν διδακτοῖς πνεύματος). See 2:12b on ἀλλὰ (*but*).

The reference to the Spirit lacks the article to give it extra (contrastive) prominence (NonNarr §6.1.3).

2:13c *combining/interpreting spiritual things with spiritual things* (πνευματικοῖς πνευματικὰ συγκρίνοντες). A **post**-nuclear participial clause, so NOT backgrounded with respect to 13a-b. See Trail pp. 107f for a summary of possible meanings for this proposition.

The order of constituents is marked but ambiguous. Since 13a-b talks of *words ... taught by the Spirit*, I would have expected the referent of the first pre-verbal constituent to be established information (hence, 'in spiritual words' [*TrNotes*], rather than 'to spiritual people', as a translation of πνευματικοῖς). The DFE would then be either πνευματικὰ ('spiritual truths'—*TrNotes*) or, more likely, the postposed verb συγκρίνοντες (*combining/interpreting*).

¹⁸ Although 12a does build on 10a (which is supported by 10b-11), it is not accurate to say that δὲ 'shows that Paul is going to go back to something he said before and talk about it more' (*TrNotes*). That is the function of οὖν (see DFNTG §7.4 p. 128 for discussion of this point).

However, the content of 14 makes me favour Trail's Option 4. This reflects the position of *ICC* (p. 47), which considers πνευματικοῖς to be in a 'markedly emphatic position' and to mean 'to spiritual hearers'. If this option is followed, then πνευματικοῖς must be focal, and given extra (contrastive) prominence: interpreting spiritual things to **spiritual** people, not unspiritual ones.

2:14a *Now/But an unspiritual person does not receive the gifts of God's Spirit* (ψυχικὸς δὲ ἄνθρωπος οὐ δέχεται τὰ τοῦ πνεύματος τοῦ θεοῦ). Δὲ signals further progression in Paul's reasoning, as he moves from the nature of the words we teach (12-13) to the nature of the recipients.

The subject-topic precedes the verb to signal a switch of attention (NonNarr §4.3.2).

2:14b *for they are foolishness to him* (μωρία γὰρ αὐτῷ ἐστίν). As usual, γὰρ (*for*) indicates that what follows (here, the rest of 14) strengthens previous material (14a).

The focal constituent μωρία (*foolishness*) is preposed to give it extra (contrastive) prominence. Consequently, the pronominal constituent αὐτῷ (*to him*) also precedes the verb (*DFNTG* §3.7 p. 39).

2:14c *and he is unable to understand them* (καὶ οὐ δύναται γινῶναι). Καὶ associates 14c with 14b, as the material that strengthens 14a continues (see NonNarr §3.1.2).

2:14d *because they are spiritually discerned* (ὅτι πνευματικῶς ἀνακρίνεται). The connective ὅτι introduces material that interprets 14c by giving a reason or evidence for it.

The DFE πνευματικῶς (*spiritually*) is preposed to give it extra (contrastive) prominence.

2:15a *But the spiritual person discerns all things* (ὁ δὲ πνευματικὸς ἀνακρίνει [τὰ] πάντα). Δὲ σιγναλς φυρτέρ προγρεσσιον ιν Παυλῆ ρεασονινγ, ας ἔ μοσεσ φρομ *an unspiritual person* (14) *to the spiritual person*.

The subject is pre-verbal to signal the switch of topic from *an unspiritual person*.

2:15b *and/but he is himself subject to no one else's scrutiny* (αὐτὸς δὲ ὑπ' οὐδενὸς ἀνακρίνεται). Δὲ signals yet further progression in Paul's argument.

The proposition has the same subject as 15a, so αὐτὸς (*he himself*) is a point of departure by renewal (NonNarr §4.3.2), introducing a contrasting comment about the spiritual person.

The negative constituent ὑπ' οὐδενὸς (*by no one*) is the DFE (*DFNTG* §4.1 p. 49).

2:16a *For who has known the mind of the Lord* (τίς γὰρ ἔγνω νοῦν κυρίου). Γὰρ (*for*) indicates that 16 strengthens previous material (15a or 15b—Trail p. 113). 'Paul uses Isaiah 40:13 to show that what he said in 2:15b is correct' (*TrNotes*).

Using a rhetorical question gives prominence to its underlying assertion (NonNarr §7.7.4).

2:16b *who/that he will instruct him?* (ὃς συμβιβάσει αὐτόν;). The proposition in Greek is a non-restrictive relative clause with the same subject as before (ὃς *who*). The relative clause is 'continuative' (*DFNTG* §11.2 p. 191), and has the effect of backgrounding 16a with respect to 16b.

2:16c *But we have the mind of Christ* (ἡμεῖς δὲ νοῦν Χριστοῦ ἔχομεν). Δὲ signals further progression in Paul's argument, this time, **within** the material that supports 15a or 15b (draft SSA of 2:14-16; see Hoopert p. 258).¹⁹

The pre-verbal subject pronoun ἡμεῖς (*we*) signals a switch of topic from the implied 'no one' of 16a-b (*TrNotes*).

The DFE νοῦν Χριστοῦ (*mind of Christ*) is preposed to give it extra (contrastive) prominence. The omission of the article increases this prominence. This means that *UBS* is wrong in asserting, 'The Greek sentence, however, does not stress **Christ** but **we**' (p. 55).

¹⁹ Fee (p. 117) perceives a chiasm in 15-16: A: 15a, B: 15b, B': 16a-b, A': 16c.

(3:1-23 On Divisions in the Corinthian Church)

Supporting evidence for the beginning of a new sub-unit at 3:1 includes the pre-verbal subject pronoun ἐγὼ (*I*— NonNarr §§8.2 & 8.8), the vocative ἀδελφοί (*brothers*—§8.9), and the shift of person and tense (from 1st plural to singular and from present to past—§8.11). However, the connective καὶ associates what follows with the previous material (‘The καὶ carries us back to ii.14: “A natural man does not receive the things of God..., and I (accordingly) could not utter (them) to you as to spiritual (men), but as to men of flesh’—Findlay 1900(1980):785). ‘Paul does nothing more than apply to himself, in his relation to the Corinthians, what he has just said of the relation of the spiritual man to purely natural man’ (Godet p. 164).

The following is a flow chart for 2:14-3:4.

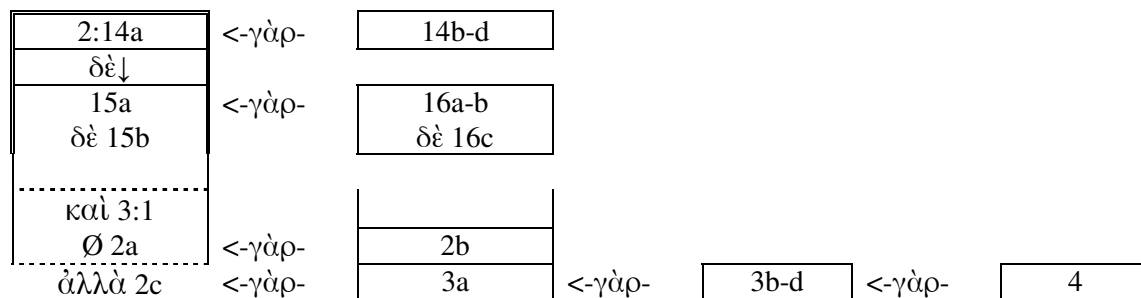

3:1a *And I, brothers, could not speak to you as spiritual people* (Κἀγὼ, ἀδελφοί, οὐκ ἠδυνήθην λαλήσαι ὑμῖν ὡς πνευματικοῖς). The subject precedes the verb to signal a switch of topic from the *we* (inclusive) of 2:16c (NonNarr §4.3.2): ‘And I, for my part’ (*TrNotes*).

Once again, the non-initial position of the vocative ἀδελφοί (*brothers*) may give prominence to what follows (the rest of 1) (§7.7).

3:1b *but rather as fleshly* (ἀλλ’ ὡς σαρκίνοις). See 2:12b on ἀλλὰ (*but*).

3:1c *as infants in Christ* (ὡς νηπίοις ἐν Χριστῷ).

3:2a *I fed you milk, not solid food* (γάλα ὑμᾶς ἐπότισα, οὐ βρωμα). The absence of a connective (asyndeton) is consistent with 2 being an amplification of 1 (‘Paul explains ν(πιοι in an expanded metaphor’—Conzelmann 1975:72).

The DFE, γάλα (*milk*) is proposed to give it extra (emphatic) prominence: ‘It was milk that I fed you, not solid food’. Consequently, the pronominal constituent ὑμᾶς (*you*) also precedes the verb (*DFNTG* §3.7 p. 39).

3:2b *for you were not yet able* (οὐπω γὰρ ἐδύνασθε). Γὰρ (*for*) indicates that 2c strengthens 2a-b.

3:2c *And you are still not able even now* (ἀλλ’ οὐδὲ ἔτι νῦν δύνασθε). The countering connective ἀλλὰ (which NSRV appropriately translates ‘Yes, and’ in Phil. 1:18c) indicates that what follows is ‘contrary to nature and to expectation’ (Lanski p. 123).

Οὐδὲ ‘neither, nor’ is a negative additive (*DFNTG* §6.3), here adding *still now* to the past.

The focal constituents ἔτι νῦν (*still now*) are preposed, following οὐδὲ, for extra prominence (emphatic, as this is surprising) (*DFNTG* §4.1).

3:3a *for you are still fleshly* (ἔτι γὰρ σαρκικοί ἐστε). Γὰρ (*for*) indicates that what follows (3-4) strengthens 2c (Hoopert pp. 260-61).

Repetition or paraphrase of a key mainline thesis highlights that thesis; the assertion in 3:1 that the Corinthians are *fleshly* is repeated in 3a and 3c,²⁰ as well as being paraphrased in 3d and 4 (οὐκ ἄνθρωποί ἐστε; *are you not [merely] human?*) (NonNarr §7.7.2). The DFE of 3a is ἔτι (*yet*).²¹

²⁰ See Trail p. 120 on a possible difference between the two words for *fleshly*: σαρκίνοις (1b) and σαρκικοί (3a).

3:3b *For as long as among you there is jealousy and quarrelling* (ὅπου γὰρ ἐν ὑμῖν ζήλος καὶ ἔρις). As γὰρ (*for*) indicates, 3b-4 now strengthens 3a, which itself was strengthening 2c. ‘How does Paul know that the Corinthian believers are still worldly? In 3:3b he gives proof/evidence’ (*TrNotes*).

The pre-nuclear reason clause signals a switch of situation from that of 1-2 (*DFNTG* §2.2). The proposition has presentational articulation; it presents or (re)introduces the entities ζήλος καὶ ἔρις (*jealousy and quarrelling*) into the argument (NonNarr §2.1—compare 1:11b). This explains why the (focal) subject is final in the proposition, in conformity with the Principle of Natural Information Flow.

3:3c *are you not fleshly* (οὐχὶ σαρκικοί ἐστε). Using a rhetorical question gives prominence to its underlying assertion (NonNarr §7.7.4). The focal constituent (σαρκικοί *fleshly*) is preposed for extra prominence (*DFNTG* §4.1 p. 51).

3:3d *and walk according to human inclinations?* (καὶ κατὰ ἄνθρωπον περιπατεῖτε;). Καὶ (*and*) is associative (NonNarr §3.1.2), as 3c and 3d together strengthen 3a. It is misleading to say that it indicates an explanation of 3c (Trail p. 122), though, as *UBS* (p. 59) notes, this does NOT mean ‘that something new is to be said’ in 3d.

The focal constituent (κατὰ ἄνθρωπον *according to human inclinations*) is again preposed for extra prominence.

3:4 *For whenever someone says “I belong to Paul” and another, “I belong to Apollos”* (ὅταν γὰρ λέγῃ τις, Ἐγὼ μὲν εἶμι Παύλου, ἕτερος δέ, Ἐγὼ Ἀπολλῶ). As γὰρ (*for*) indicates, 4 now strengthens 3b-d; ‘each such utterance is one more verification (γ(ρ) of the indictment’ (*ICC* p. 54).

A complex temporal construction, signalling a switch of situation from the generic one of 3b to a specific instance of *jealousy and strife*) (*DFNTG* §2.2).

3:4a *whenever someone says* (ὅταν λέγῃ τις). The subject follows the verb as there is topic continuity, with attention still on *you* [plural] and your carnality (NonNarr §4.3.2).

3:4b *“I belong to Paul”* (Ἐγὼ μὲν εἶμι Παύλου). As in 1:12c, the pre-verbal subject pronoun Ἐγὼ centres the attention on *I*, in contrast to others (also in 4d).

On the use of μὲν (*on the one hand*), which anticipates the corresponding sentence containing δέ (*on the other hand*—4c), see the comments on 1:12.

3:4c-d *and another, “I belong to Apollos”* (ἕτερος δέ, Ἐγὼ Ἀπολλῶ). The initial subject signals a switch of topic from *τις* (*someone*—4a).

3:4e *are you not human?* (οὐκ ἄνθρωποι ἐστε). As usual when a focal constituent precedes its verb, it is given more prominence than when it follows the verb (Meyer p. 67; see *DFNTG* §3.7 p. 38 on pre-verbal complements in copular clauses).

3:5. Supporting evidence for the beginning of a new sub-unit at 3:5 includes the connective οὖν (*then*—NonNarr §8.3) and the use of a rhetorical question (§8.7). In addition, Terry (pp. 43f) finds high-level chiasmus in 1:10-3:4 and 3:5-4:17 (§8.6). In particular, there is an *inclusio* between 1:11-12 & 3:3-4.

When οὖν follows supportive material introduced by γὰρ (*for*), it invariably indicates a resumption and further development of the same theme line that was being supported (‘Its function here is not to introduce a logical deduction, but to show that Paul is passing to another aspect of the same theme’—*UBS* p. 61; *DFNTG* §7.4). In this passage, Paul’s last THESIS was that the Corinthians were still not ready for solid food (2). Having explained why this is so (3-4), 5-6 represent the next step in his reasoning.

²¹ The default position of ἔτι is before the verb, anyhow.

The following is a flow chart for 3:1-7.

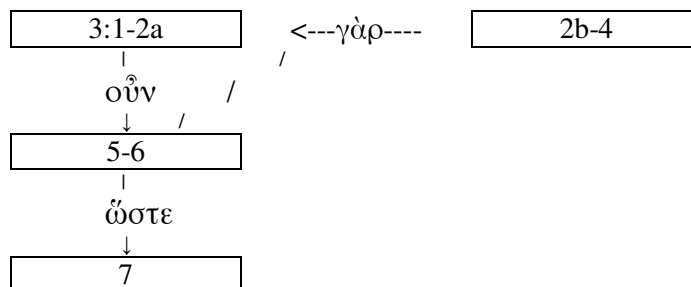

However, because of the *inclusio* between 1:11-12 and 3:3-4, the theme line being resumed may be that of 1:13.

3:5a *What is Apollos?* (τί ἐστὶν Ἀπολλῶς;). The introduction of a question that is then answered highlights the following assertion: *Servants through whom you came to believe, and to each as the Lord assigned* (NonNarr §7.7.4).

3:5b *And what is Paul?* (τί δέ ἐστὶν Παῦλος;). The use of δέ, rather than associative καί, signals progression in Paul’s reasoning from Apollos to himself (DFNTG §7.1).

3:5c *Servants through whom you came to believe* (διάκονοι δι’ ὧν ἐπιστεύσατε).

3:5d *and to each as the Lord assigned* (καὶ ἐκάστῳ ὡς ὁ κύριος ἔδωκεν). Associative καὶ adds a second answer to the questions of 5a-b (‘The answer is in two parts’—Fee p. 130).

ἐκάστῳ (*to each*) is preposed to establish a point of departure for what follows²² (‘Paul is thus anticipating the division of labor that he will speak to in vv. 6-8, and means something like: “and each servant worked according to the task given him by Christ himself”’ (ibid. p. 131).

The order of constituents within the subordinate clause (ὡς ὁ κύριος ἔδωκεν *as the Lord assigned*) is marked but ambiguous. Fee’s rendering (above) treats ‘by Christ himself’ as the DFE. Alternatively (since ὁ κύριος has the article), the verb is postposed for extra prominence. Since the verbs in 6a-c are focal, this is not an unreasonable interpretation.

3:6a *I planted* (ἐγὼ ἐφύτευσα). The absence of a connective (asyndeton) is consistent with 6 being an amplification of 5d (‘the verse reaffirms in a new form the last proposition of ver. 5’—Godet p. 174).

The pre-verbal subject pronoun signals a switch of topic from *the Lord* to *I* (NonNarr §4.3.2). This is how ‘The pronoun *I* is emphatic here’ (*TrNotes*) should be understood.

3:6b *Apollos watered* (Ἀπολλῶς ἐπότισεν). The pre-verbal subject signals a switch of topic from *I* to Apollos (NonNarr §4.3.2).

3:6c *but God gave the growth* (ἀλλὰ ὁ θεὸς ἠύξανεν). When ἀλλὰ follows a **positive** proposition, it ‘corrects an expectation’ (Heckert 1996:22), but is still associative, in the sense that it does not signal a new development in the argument... The first pair of propositions (*I planted, Apollos watered*) is not discarded or replaced by the one introduced with ἀλλὰ (*God gave the growth*). Rather, 7 relates to both parts of the contrast (*So neither the one who plants nor the one who waters is anything, ἀλλὰ only God who gives the growth*) and, in 8, the topic is back to *The one who plants and the one who waters*.

The pre-verbal subject signals a switch of topic from *I* and *Apollos* to *God*. ‘There is no significant contrast between Paul and Apollos; both are contrasted with God’ (*UBS* p. 62).

3:7a *So neither the one who plants nor the one who waters is anything* (ὥστε οὔτε ὁ φυτεύων ἐστὶν τι οὔτε ὁ ποτίζων). The conjunction ὥστε introduces the **concluding** THESIS of the section. ‘Now

²² It is in this sense that Findlay’s (p. 788) claim, ‘ἐκάστῳ is emphatically projected before the ὡς’ is to be understood.

verse 7 states the conclusion that neither Paul the planter, nor Apollos the waterer, is important; but God is the one who "made the plant grow" (UBS p. 62).

It is normal in Greek for the first part of a co-ordinative focal constituent to begin a proposition and be separated from the second part by the verb or another constituent (DFNTG §4.4.1 pp. 57f). In this instance, the two parts are linked with οὔτε ... οὔτε *neither ... nor*.

3:7b *but only God who gives the growth* (ἀλλ' ὁ ἀυξάνων θεός). See 2:12b on the use of ἀλλὰ (*but*) following negative propositions. By specifying that *the one who gives the growth* is *God*, extra prominence is given to the constituent as a whole.

3:8a *Now the one who plants and the one who waters are one* (ὁ φυτεύων δὲ καὶ ὁ ποτίζων ἓν εἶσιν). Having concluded one point in his argument (7), δὲ signals progression to the next ('This means that Paul here begins to make a new point in the metaphor he began in 3:6'—*TrNotes*).

The pre-verbal subject signals a switch of topic from *God* (7b) back to that of 7a.

The focal constituent ἓν (*one*) is preposed to give it extra prominence, probably of a contrastive nature ('the wider context of this chapter contrasts the unity of the evangelists' work with the disunity of the parties in Corinth'—UBS p. 63).

3:8b *and each will receive his own wages according to his own labour* (ἕκαστος δὲ τὸν ἴδιον μισθὸν λήμψεται κατὰ τὸν ἴδιον κόπον). Δὲ again signals progression in Paul's argument, as he moves from them sharing the same work to 'the difference of the reward they will receive' (Godet p. 176).

The pre-verbal subject signals a switch of topic from Paul and Apollos together (8a) to each of them individually.

The DFE τὸν ἴδιον μισθὸν (*his own wages*) is preposed to give it extra prominence.

3:9a *For we are God's co-workers* (θεοῦ γὰρ ἐσμεν συνεργοί). Γὰρ (*for*) indicates that what follows strengthens the previous material (see Trail p. 131 for the possibilities).

The genitive θεοῦ is preposed within the focal constituent and lacks the article to give it extra prominence (DFNTG §4.5 p. 62 & §9.3 p. 162). The constituent θεοῦ ... συνεργοί (*of God ... co-workers*) is also discontinuous because only the first part is given extra prominence (ibid. §4.4.2 p. 58).

3:9b-c *you are God's field, God's building* (θεοῦ γεώργιον, θεοῦ οἰκοδομή ἐστε). It is inappropriate to introduce a paragraph break between 9b and 9c (TEV, NEB), since there is parallelism between the two propositions. The absence of any connective (asyndeton) is consistent with 9b-c being parallel statements with 9a, too (see Hoopert p. 264).

As in 9a, the genitive θεοῦ (*of God*) is preposed (twice) within the focal constituent and lacks the article to give it extra prominence. The repetition of θεοῦ from 9a also gives it prominence (NonNarr §7.7.2).

3:10. The situational points of departure Κατὰ τὴν χάριν τοῦ θεοῦ τὴν δοθεῖσάν μοι and ὡς σοφὸς ἀρχιτέκτων *According to the grace of God given to me and as a skilled master builder* (10a-b—NonNarr §8.2) and the absence of a connective (asyndeton—§8.3) provide supporting evidence for the beginning of a new sub-unit at 3:10.

No connective is used because '[the] apostle first looks backwards (*I laid*)' (Godet p. 179). In other words, 10a-b is a flashback to the past, before Paul returns to the present (10c).

The following is a flow chart for 3:10-15 (the details of 12-15 are not spelt out).

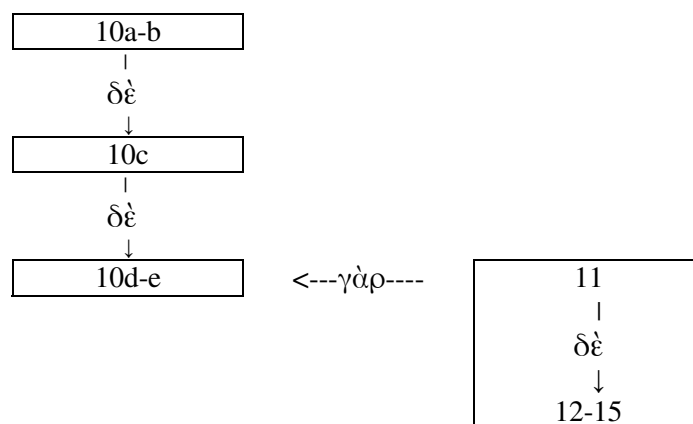

3:10b *I laid a foundation* (θεμέλιον ἔθηκα). The order of constituents is marked but ambiguous. It is possible that θεμέλιον (*a foundation*) is preposed to give it extra prominence (it is a foil, to set off *is building* to advantage by contrast—NonNarr §5.2.1).

3:10c *and someone else is building on it* (ἄλλος δὲ ἐποικοδομεῖ). Δὲ signals progression of thought through the verse (DFNTG §7.1) from what Paul had done in the past to what is happening in the present (10c) and then to the exhortation of 10d-e.

The pre-verbal subject signals a change of topic from *I* (10b).

3:10d-e *Now let each one choose with care how he builds on it* (ἕκαστος δὲ βλέπετω πῶς ἐποικοδομεῖ). A 3rd person imperfective (‘present’) imperative—something that the builders are to keep on doing (NonNarr §7.2.2).

The pre-verbal subject signals a change of topic from *someone else* (10c).

3:11a *For no one can lay any foundation other than the one that has been laid* (θεμέλιον γὰρ ἄλλον οὐδεὶς δύναται θεῖναι παρὰ τὸν κείμενον). The strengthening material introduced by γὰρ relates to the exhortation of 10d-e, but it is 12 that relates directly to the exhortation, rather than 11, so 11 may be a counterpoint for 12-15 (NonNarr §3.3). ICC reflects this by using a subordinate clause to render 11a: ‘Let each man look to it how he builds upon this foundation, because, although (I grant, nay, I insist) none can lay *any foundation* παρὰ τὸν κείμενον, yet the superstructure is a matter of separate and grave responsibility’ (p. 61).

θεμέλιον ἄλλον ... παρὰ τὸν κείμενον (*foundation other beside the one being laid*). ‘The constituent is discontinuous because only the second part relates to what follows’ (DFNTG §4.4.2 p. 58). Lenski treats θεμέλιον as a point of departure: ‘as regards foundation, no one can lay another...’ and separates it from ἄλλον (*other*) because it follows the noun (pp. 135f). However, it is not unusual for ἄλλος to follow a noun and modify it (see 1:16, for example). So it is more likely that the whole of Θεμέλιον ἄλλον is a focal constituent that has been preposed for extra (contrastive) prominence.

As for the pre-verbal subject οὐδεὶς (*no one*), that is probably focally prominent, too. Such prominence can be captured by translating 11a into English with a cleft construction with presentational articulation²³: *There is **no other foundation** than the one that has been laid that **anyone** can lay.*

3:11b *which is Jesus Christ* (ὅς ἐστὶν Ἰησοῦς Χριστός). A non-restrictive relative clause used in connection with sequential progression, in which a constituent of the comment of one proposition (here, *the one [foundation] that has been laid*) becomes topical in the next. The relative clause may be continuative, with the effect of backgrounding 11a with respect to 11b.

²³ Compare Fee (p. 139): ‘there cannot be “any foundation other than the one already laid...”’.

3:12 *Now if anyone builds on the foundation with gold, silver, precious stones, wood, hay, straw* (εἰ δέ τις ἐποικοδομεῖ ἐπὶ τὸν θεμέλιον χρυσόν, ἄργυρον, λίθους τιμίους, ξύλα, χόρτον, καλάμην). I take δέ to be marking progression within the supportive material of 11-15 (Trail's second option—p. 136).

The pre-nuclear conditional clause signals a switch from the situation of 11a (laying a foundation) to building on it. Within the clause, the pre-verbal subject signals a switch of topic from that of 11b.

The object is the DFE and follows the adjunct, in conformity with the Principle of Natural Information Flow (NonNarr §4.4).

3:13a *the work of each one will become visible* (ἐκάστου τὸ ἔργον φανερόν γενήσεται). The pre-verbal subject signals a switch of topic from that of 12. Within the subject-cum-topic, the genitive ἐκάστου (*of each one*) is preposed for thematic prominence (NonNarr §5.5). 'Individual responsibility is again insisted upon' (ICC p. 63). (Also in 13d.)

3:13b *for the Day will disclose it* (ἢ γὰρ ἡμέρα δηλώσει). Γὰρ introduces supportive material that strengthens 13a ('3:13c gives the reason everyone will be able to see the quality of work each worker has done' —*TrNotes*).

The order of constituents is marked but ambiguous (DFNTG §3.8). One could argue that *disclose* is related semantically to *become visible* (13a), whereas ἡ ἡμέρα *the Day* is non-established information, in which case the subject would be the DFE, preposed for extra prominence (comparable to 'It will be disclosed on the Day [of judgement]'). Alternatively, the subject is pre-verbal to signal a change of topic, in which case the verb is focal. This interpretation is consistent with translations such as 'On the day/time when Christ judges all things, he will expose the quality of every person's work' (*TrNotes*).

3:13c *because it will be revealed with fire* (ὅτι ἐν πυρὶ ἀποκαλύπτεται). The material introduced by ὅτι interprets 13b by giving a reason or evidence for the last assertion (13b).

The order of constituents is again marked but ambiguous. Since *be revealed* is related semantically to *become visible* and *disclose*, whereas ἐν πυρὶ is non-established information, it must be the DFE, preposed for extra prominence.

3:13d *and the fire will test each one's work of what sort it is* (καὶ ἐκάστου τὸ ἔργον ὁποῖόν ἐστιν τὸ πῦρ [αὐτὸ] δοκιμάσει). The reason for 13b continues into 13d, so the associative conjunction καὶ is used.

The preposed object ἐκάστου τὸ ἔργον (*each one's work*) establishes a referential point of departure for the rest of the proposition. If *it* in 13c refers to *the day* (Trail's first option on p. 140), then the point of departure signals a switch of patient. Within the object, the genitive ἐκάστου (*of each one*) is again preposed for thematic prominence (see 3:13a).

Two focal constituents appear to have been given extra prominence within this proposition: preposed ὁποῖόν (*of what sort*) and the postposed verb δοκιμάσει (*will test*).

3:14-15. The absence of a connective is consistent with 14-15 being an amplification of *each one's work of what sort it is* (13d), as 'Paul spells out the results of the "testing by fire"' (Fee p. 142).

3:14a *If the work of anyone that he built on survives* (εἴ τινος τὸ ἔργον μενεῖ ὃ ἐποικοδόμησεν). The pre-nuclear conditional clause signals a switch of situation to one of the results of being tested by fire.

Τινος τὸ ἔργον (*the work of anyone*) is a referential point of departure by renewal as Paul moves from a general statement about *each one's work* to one which applies only to a sub-group. As in 13a and 13d, the genitive τινος (*of anyone*) is preposed within the subject-cum-topic. (Also in 15a.)

I think the attributive clause ὃ ἐποικοδόμησεν (*that he built on*) occurs at the end of the clause for clarification (it 'reminds us that the work examined was built on the one foundation' —Findlay p. 792).

3:14b *he will receive a reward* (μισθὸν λήμψεται). The DFE μισθὸν (*a reward*) is preposed to give it extra prominence (in anticipation of the contrast with 15a).

3:15a *If the work of anyone is burned up* (εἴ τινος τὸ ἔργον κατακαήσεται). The absence of a connective is consistent with 15 being parallel to 14 (Fee p. 142).

The pre-nuclear conditional clause signals a switch of situation from that of 14a.

3:15b *he will suffer loss* (ζημιωθήσεται).

3:15c-d *he himself will be saved, but thus as through fire* (αὐτὸς δὲ σωθήσεται, οὕτως δὲ ὡς διὰ πυρός). Δὲ signals progression within the description of the outcome of the testing by fire, as Paul builds up to his conclusion in 15d: ‘the reward will be lost, but the worker himself will be saved ... But only as one passing through fire is saved’ (ICC p. 65).

3:15c *he himself will be saved* (αὐτὸς σωθήσεται). The preposed subject pronoun αὐτὸς (*he*) is a referential point of departure by renewal, introducing a distinctive (contrasting) comment about the same subject-cum-topic.

3:15d *but thus as through fire* (οὕτως δὲ ὡς διὰ πυρός). Whether the proximal demonstrative οὕτως (‘thus, in this way’) is cataphoric or anaphoric (Trail’s second and third options—p. 144), the rhetorical effect is the same: it is a slowing down device whose effect is to highlight Paul’s final assertion (NonNarr §7.7).

3:16. The absence of a connective (asyndeton—NonNarr §8.3), the use of a rhetorical question and the orienter οὐκ οἶδατε (*Do you not know*—§§8.7 & 8.10), together with the shift of person from 3rd to 2nd (§8.11), provide good supporting evidence for the beginning of a new sub-unit at 3:16.

The absence of a connective implies that ‘the question of vs. 16 is not directly connected with the immediately preceding context but goes back to vs. 9, *God’s building*’ (Grosheide p. 88). However, Godet (p. 192) considers the asyndeton (here, and in 17 and 18) to represent an ‘abrupt transition’ that ‘betrays emotion’ (see *DFNTG* §7.2 p. 121, citing Callow 1992:192).

3:16a-b *Do you not know that you a temple of God* (οὐκ οἶδατε ὅτι ναὸς θεοῦ ἐστε). This type of rhetorical question gives **emphatic** prominence to its underlying assertion. Fee claims that Paul uses it in this letter ‘chiefly in contexts where he is exercised’ (p. 146).

Pre-verbal complements in copular clauses receive more prominence than when they follow the verb (*DFNTG* §3.7 p. 38). The omission of the article in ναὸς θεοῦ (*a temple of God*) increases the prominence (NonNarr §6.1.3).

3:16c *and that the Spirit of God dwells in you?* (καὶ τὸ πνεῦμα τοῦ θεοῦ οἰκεῖ ἐν ὑμῖν;). Καὶ associates 16b and 16c together (see *TrNotes* for a possible way to relate the two propositions).

3:17a *If anyone destroys the temple of God* (εἴ τις τὸν ναὸν τοῦ θεοῦ φθείρει). The absence of a connective may again reflect the emotional nature of this passage (Godet p. 193).

The pre-nuclear conditional clause signals a switch to a new situation.

The repetition from 16b of *temple of God* here and in 17c gives (thematic) prominence to the phrase (NonNarr §7.7.2). Nevertheless, the use of the article and the order of constituents (which conforms to the Principle of Natural Information Flow) show that it is the verb that is focal.

3:17b *God will destroy that person* (φθερεῖ τοῦτον ὁ θεός). The subject follows the verb as there is topic continuity, with attention still on anyone who attempts to destroy God’s temple (NonNarr §4.3.2). Furthermore, the order of constituents conforms to the Principle of Natural Information Flow (NonNarr §4.4), since *God* was not an active participant in the action of 17a.²⁴

²⁴ However, Findlay (p. 793) says, ‘ὁ θεός closes the warning, with awful emphasis’ (p. 793).

Paul uses the proximal demonstrative τοῦτον to mark *this person* (contrast the NRSV translation) as the current centre of attention ('thematic'—NonNarr §6.1).²⁵ Fee suggests that the referent is 'the prime movers of the present quarrelings' (p. 148).

3:17c *For the temple of God is holy* (ὁ γὰρ ναὸς τοῦ θεοῦ ἅγιός ἐστιν). Γὰρ introduces supportive material that strengthens 17b.

The pre-verbal subject signals a change of topic from *anyone* (17a) and *God* (17b).

The focal complement ἅγιός (*holy*) is preposed to give it extra prominence.

3:17d *which (plural) you are* (οἵτινές ἐστε ὑμεῖς). A non-restrictive relative clause (NonNarr §10.3.4), which forms an *inclusio* with 16b. See Trail pp. 147f for discussion of whether its referent is *temple* or *holy*.

The presence of the pronoun ὑμεῖς certainly gives some prominence to the focal constituent *you*. However, failure to prepose the pronoun means that it is not as prominent as it could have been.

3:18. The absence of a connective (asyndeton— NonNarr §8.3), the *inclusio* in 16-17 (§8.5) and shift of mood from declarative to imperative (§8.11) provide supporting evidence for the beginning of a new sub-unit at 3:18.

Asyndeton is consistent with Paul starting 'a new thought here' (*TrNotes*). However, it may again reflect the emotional nature of this passage (Godet p. 195).

The following is a flow chart for 3:18-23.

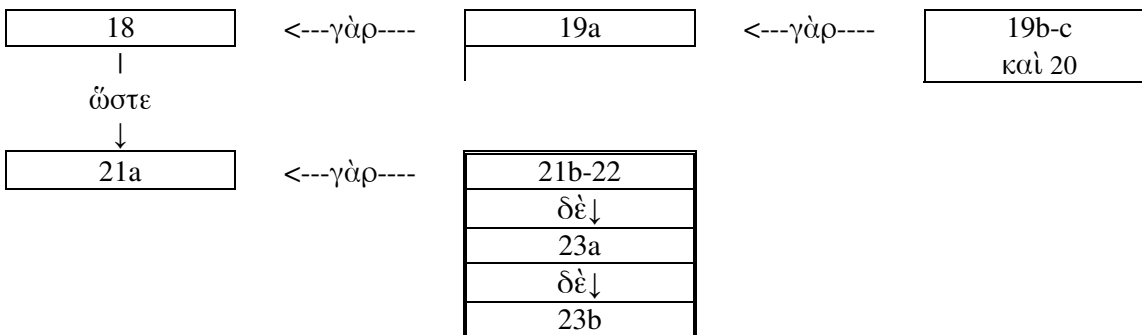

3:18a *Let no one deceive himself* (Μηδεὶς ἑαυτὸν ἐξαπατάτω). A 3rd person imperfective ('present') imperative used as an attention getter (NonNarr §7.2.1-2), to draw attention to what follows (the exhortation of 18c, which relates back to the types of wisdom discussed in 1:18ff) (§7.7).²⁶

The order of constituents is marked but ambiguous. I judge the verb to be the DFE, postposed for extra prominence.

3:18b *If anyone among you thinks that he is wise in this age* (εἴ τις δοκεῖ σοφὸς εἶναι ἐν ὑμῖν ἐν τῷ αἰῶνι τούτῳ). The absence of a connective is consistent with the 18a being an attention getting orienter for what follows, as well as it being in a contraction-AMPLIFICATION relation with 18b-d.

The pre-nuclear conditional clause signals a switch back to a situation discussed in 1:19ff.

The pre-verbal subject probably signals a switch of topic from the *anyone* of 17a and *the temple of God* (17c).

The DFE σοφὸς (*wise*) is preposed to give it extra prominence, in anticipation of the contrast with *a fool* in 18c.

3:18c *he should become a fool* (μωρὸς γενέσθω). This 3rd person imperative is perfective ('aorist'), as the change of state needs to be achieved only once (NonNarr §7.2.1-2).

²⁵ 'Him is emphatic' (*UBS* p. 69) is to be understood in this sense.

²⁶ However, Hoopert (p. 269) treats 18a as the contracted equivalent of the exhortation of 18b-d. A few commentators relate 18a to the previous context (see Trail p. 149).

The DFE μωρός *a fool* is preposed to give it extra (contrastive) prominence (NonNarr §5.2.1).

A few commentators consider 18c to begin with the temporal expression ἐν τῷ αἰῶνι τούτῳ (*in this age*—see 18b). If so, then it signals a switch of situation from *among you* (‘by the standards of your group’) to ‘by this world’s standards’ (UBS p. 71).

3:18d *so that he may become wise* (ἵνα γένηται σοφός). (Default constituent order.)

3:19a *For the wisdom of this world is foolishness with God* (ἡ γὰρ σοφία τοῦ κόσμου τούτου μωρία παρὰ τῷ θεῷ ἐστίν). Γὰρ introduces supportive material that strengthens the exhortation of 18b (‘Paul now gives the theological basis for the preceding exhortation’—Fee p. 152).

The pre-verbal subject signals a switch of topic from the *anyone* of 18b-d.

The focal constituent μωρία παρὰ τῷ θεῷ (*foolishness with God*) is preposed to give it extra (contrastive) prominence.

3:19b *For it is written* (γέγραπται γάρ). Γὰρ introduces supportive material that strengthens the assertion of 19a (see *TrNotes*).

3:19c *The one who catches the wise in their craftiness* (Ὁ δρασσόμενος τοὺς σοφοὺς ἐν τῇ πανουργίᾳ αὐτῶν).

3:20a *and again* (καὶ πάλιν). Καὶ associates the two OT quotations together, as both relate to the assertion of 19a. ‘This quotation, even more than the first, develops and supports the statement in verse 19a about “what God calls folly”’ (UBS p. 72).

3:20b *The Lord knows the thoughts of the wise* (Κύριος γινώσκει τοὺς διαλογισμοὺς τῶν σοφῶν). The pre-verbal subject in the Hebrew and LXX is a referential point of departure by renewal, as it introduces distinct comments about *the Lord*. It probably lacks the article because κύριος in the LXX translates YHWH.

3:20c *that they are futile* (ὅτι εἰσὶν μάταιοι). This proposition interprets 20b (the function of ὅτι) in the sense that it spells out what *the thoughts of the wise* are.

3:21a *So let no one boast in men* (ὥστε μηδεὶς καυχάσθω ἐν ἀνθρώποις). ὥστε (*So*) ‘introduces the conclusion of Paul’s argument’ (UBS p. 72), ‘referring back to what he said in 1:12’ (*TrNotes*).

A 3rd person imperfective (‘present’) imperative—‘something that the Corinthians are to keep on not doing’ (NonNarr §7.2.1-2).

3:21b-22b form an *inclusio* (NonNarr §4.1).

Γὰρ (*For*) introduces supportive material that strengthens the exhortation of 21a. What follows ‘gives the reason believers should not proudly say they follow one teacher and not another’ (*TrNotes*).

3:21b *all things are yours* (πάντα ὑμῶν ἐστίν). As 22a makes clear, πάντα *all things* is focal, rather than topical. It is preposed for extra prominence (‘with the emphasis on πάντα’—Meyer p. 81). Consequently, the pronominal constituent ὑμῶν (*yours*) also precedes the verb (*DFNTG* §3.7 p. 39).

3:22a *whether Paul or Apollos or Cephas or the world or life or death or the present or the future* (εἴτε Παῦλος εἴτε Ἀπολλῶς εἴτε Κηφᾶς, εἴτε κόσμος εἴτε ζωὴ εἴτε θάνατος, εἴτε ἐνεστώτα εἴτε μέλλοντα).

3:22b *all are yours* (πάντα ὑμῶν). As in 21b, πάντα *all things* is focal, rather than topical.

3:23b *and you are Christ’s, and Christ is God’s* (ὕμεῖς δὲ Χριστοῦ, Χριστὸς δὲ θεοῦ). This verse provides an example of sequential progression, in which constituents of the comment of one sentence become topical in the next (NonNarr §4.1).

Δὲ signals ‘a further development in Paul’s talk’ (*TrNotes*), as he builds up to ‘the final crescendo’ (Fee p. 155) in 23b.

4:1-13 or 21 Apostles of Christ

Supporting evidence for the beginning of a new sub-unit at 4:1 includes the absence of a connective (asyndeton— NonNarr §8.3) and a possible shift of person (from 2nd to explicit 3rd/1st—§8.11).

After explaining what preachers *are not*... the apostle declares *what they are*' (Godet p. 203). In other words, Paul shifts to another aspect of his overall theme (see Fee p. 156), rather than further developing his line of reasoning in the final verses of chapter 3—hence the absence of a connective.

In 3 and 4c, δὲ signals progression within Paul's reasoning. Following 1-2, which set the scene for what follows, he progresses to his indifference to any form of human judgement (3-4b—Godet p. 209), and thence to his identification of *the Lord* as his judge (4c), which culminates in the exhortation of 5.

The following is a flow chart for 4:1-5.

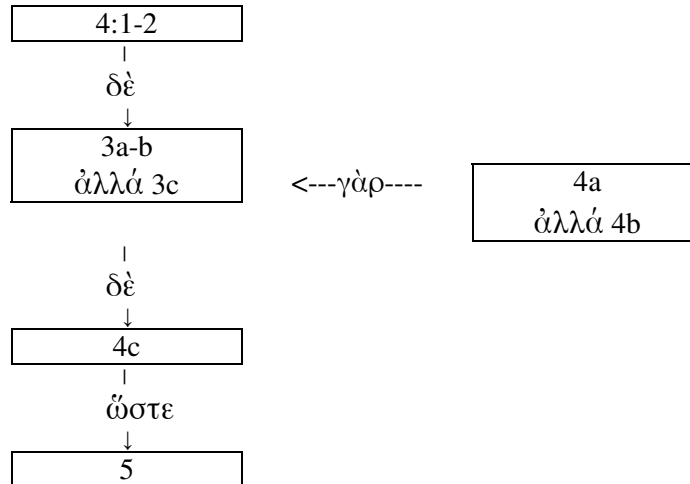

4:1a *Let a person think of us in this way* (Οὕτως ἡμᾶς λογιζέσθω ἄνθρωπος). I follow the majority of commentators in understanding the proximal demonstrative Οὕτως (*in this way*) to be cataphoric, pointing forward to 1b. It is preposed to give it extra prominence. Such a device, particularly when preposed, has the effect of highlighting 1b (NonNarr §7.7).

The subject (ἄνθρωπος) follows the verb as attention switches to *us* (pre-verbal ἡμᾶς), not *a person*. It is in this sense that ἡμᾶς is to be understood as being ‘with emphasis’ (Lanski p. 161).

4:1b *as servants of Christ and stewards of God's mysteries* (ὡς ὑπηρέτας Χριστοῦ καὶ οἰκονόμους μυστηρίων θεοῦ). The absence of an article with Χριστοῦ (*of Christ*) and θεοῦ (*of God*) gives their referents extra (contrastive) prominence (DFNGT §9.3 p. 162): *we* ‘have to give account before these supreme authorities and not before the members of the Church’ (Godet p. 205).

4:2a *Moreover, it is required of stewards* (ὡδὲ λοιπὸν ζητεῖται ἐν τοῖς οἰκονόμοις). ὡδὲ λοιπὸν is an additive expression, and may be glossed *furthermore*; it is literally, ‘here beyond’. **IF** ὡδὲ is taken literally, then it is a situational point of departure, signalling a switch from the divine (1b) to ‘on earth and in human life’ (ICC p. 75). ‘Paul may already be implying the contrast between human and divine judgment which he makes explicit later on’ (UBS p. 76).

4:2b *that they [lit. anyone] be found trustworthy* (ἵνα πιστός τις εὕρεθῆ). This exhortation, which is expressed in a final clause following the orienter ζητεῖται (*it is required*), is not directed to the Corinthians. The exhortation itself is perfective (‘aorist’), which “indicates that the person’s ministry will be looked at a whole ... when his master reviews his work” (Trail p. 163) (NonNarr §7.2.1).

The focal constituent πιστός *trustworthy* is preposed for extra prominence. Consequently, the pronominal constituent τις (*anyone*) is also preposed.

4:3a *But with me it is a very small thing* (ἐμοὶ δὲ εἰς ἐλάχιστόν ἐστιν). Δὲ signals progression within Paul's reasoning (see the introduction to 4:1-21).

The pronominal ἐμοὶ *to me* is preposed to signal a switch of attention from stewards in general (2): 'As for me, whether you or any human court judge me, it is of no importance' (*UBS* p. 77).

The focal constituent εἰς ἐλάχιστόν *a very small thing* is preposed for extra (emphatic) prominence (NonNarr §5.2.1).

4:3b *that I should be judged by you or by any human court* (ἵνα ὑφ' ὑμῶν ἀνακριθῶ ἢ ὑπὸ ἀνθρωπίνης ἡμέρας). It is normal in Greek for the first part of a co-ordinative focal constituent to begin a proposition and be separated from the second part by the verb or another constituent (*DFNTG* §4.4.1 pp. 57f). In this instance, the two parts are linked with ἢ *or*.

4:3c *Nor do I judge myself* (ἀλλ' οὐδὲ ἐμαυτὸν ἀνακρίνω). As in 3:6c, when ἀλλά follows a **positive** proposition, it corrects an expectation. Here, the Corinthians might assume that, by rejecting them or any human court, he thereby sets himself up as his own judge (see Trail pp. 165f).²⁷

As *UBS* (p. 77) notes, the negative additive οὐδὲ (*nor*) (*DFNTG* §6.3) doesn't necessarily mean 'not even': 'I refuse not only the judgment of others, *but also* that of myself' (Godet p. 209). However, the focal constituent ἐμαυτὸν is preposed for extra prominence, which could well be emphatic (see *ICC* p. 76).

4:4a *For I am aware of nothing against myself* (οὐδὲν γὰρ ἐμαυτῷ σύννοιδα). Γὰρ (*For*) introduces supportive material (4a-b) that strengthens and explains 3c (*UBS* p. 77). It does not and cannot have 'the force of δ(' (Fee p. 162, fn. 20).

The order of constituents is marked but ambiguous. Since *myself* is established information, the DFE must either be οὐδὲν (*nothing*) or the negated verb σύννοιδα (*am aware of*).

4:4b *but I am not thereby justified* (ἀλλ' οὐκ ἐν τούτῳ δεδικαίωμαι). Once again, ἀλλά corrects an expectation, this time, that having a clear conscience implies that Paul will be acquitted.

The proximal demonstrative ἐν τούτῳ (literally, 'by this') makes its referent temporarily the centre of attention (see comment on 2:2c).

The order of constituents is again marked but ambiguous. Since the referent of ἐν τούτῳ is established information and being justified or acquitted has not previously mentioned, I take the verb to be focal and prominent (contrast Godet p. 211, who translates the expression 'even for this').

4:4c *The one who judges me is the Lord* (ὁ δὲ ἀνακρίνων με κύριός ἐστιν). Δὲ signals further progression within Paul's reasoning (see the introduction to 4:1-21).

The pre-verbal subject signals a switch of attention from *I*, the subject-topic of 3-4b.

The focal constituent (κύριός *Lord*), which follows the subject, is preposed for contrastive prominence, contrasting with *you, any human court, I* in 3 and *thereby* in 4b (NonNarr §5.2.1). The absence of the article adds to the prominence.

4:5a *So do not judge anything before the time* (ὥστε μὴ πρὸ καιροῦ τι κρίνετε). ὥστε (*So*) introduces 'the conclusion of this part of Paul's argument', which is an exhortation (*UBS* p. 78). The exhortation is a 2nd person imperfective ('present') imperative—something that the Corinthians are to keep on not doing (NonNarr §7.2.1-2).

The DFE πρὸ καιροῦ (*before the time*) is preposed, following the negative particle μὴ, to give it extra (contrastive) prominence (*DFNTG* §4.1 p. 49): at that time, not now.

4:5b *before the Lord comes* (ἕως ἄν ἔλθῃ ὁ κύριος). The subject follows the verb as there is topic continuity, with attention still on the appropriate time for judging (NonNarr §4.3.2).

²⁷ See NonNarr §7.1 on ἀλλά not representing further progression in Paul's reasoning.

4:5c *who will also bring to light the things now hidden in darkness* (ὅς καὶ φωτίσει τὰ κρυπτά τοῦ σκοτούς). A non-restrictive relative clause used in connection with sequential progression, in which a constituent of the comment of one proposition (here, *the Lord*) becomes topical in the next (NonNarr §4.1). The relative clause may be continuative, with the effect of backgrounding 5b with respect to 5c.

Commentators have suggested a number of reasons for the presence of the additive καὶ (*also*) (see Trail pp. 170f). Paul is ‘appending a description of the Judge’ (Fee p. 163), so I think καὶ is confirmatory (*DFNTG* §6.2 p. 101) and could be translated into English by ‘indeed’.

4:5d *and will disclose the purposes of the heart* (καὶ φανερώσει τὰς βουλὰς τῶν καρδιῶν). The basic relationship indicated by καὶ is associative (see Trail p. 172 for the views of different commentators).

4:5e *And then the praise will come to each one from God* (καὶ τότε ὁ ἔπαινος γενήσεται ἐκάστῳ ἀπὸ τοῦ θεοῦ). ‘Often, the presence of τότε appears to highlight the fact that the event is to occur *then* and not at some previous time’ (*DFNTG* §6.1 p. 94); ‘it contrasts it with the premature judgments of the Corinthians (*before the time*)’ (Godet p. 214).

The pre-verbal subject signals a change of topic from *the Lord* (5c-d).

Although *from God* is part of the comment about *the praise* and hence, part of its focal domain (NonNarr §5.1), its position at the end of the proposition is default and the reference has the article. I therefore conclude that *from God* is NOT particularly ‘with emphasis’ (*ICC* p. 78).

4:6. The pre-verbal summary pronoun ταῦτα (*these things*— NonNarr §§8.2 & 8.4), the connective δέ (§8.3) and the vocative ἀδελφοί (*brothers*—§8.9) provide good supporting evidence for the beginning of a new sub-unit at 4:6 (see *UBS* p. 80). Δέ signals progression within Paul’s reasoning—‘the δέ introducing the conclusion and application of the whole’ (*ICC* p. 80).

The following is a flow chart for 4:1-13.

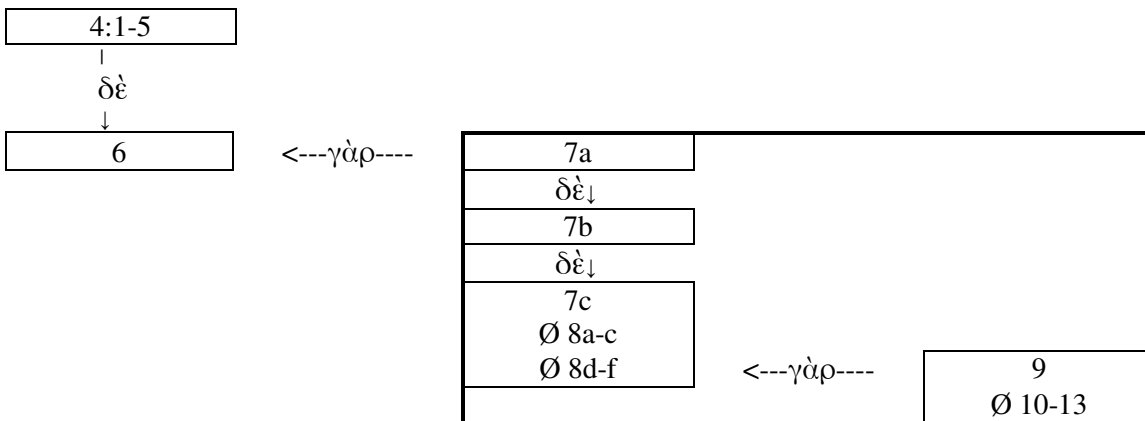

4:6a *These things, brothers, I have applied to Apollos and myself for your benefit* (Ταῦτα δέ, ἀδελφοί, μετεσημάτισα εἰς ἑμαυτὸν καὶ Ἀπολλῶν δι’ ὑμᾶς). Once again, the non-initial position of the vocative ἀδελφοί (*brothers*) may give prominence to what follows (the rest of 6).

Ταῦτα (*these things*) is proposed to signal a switch to a new point of departure: the teachings of the previous verses (most commentators favour 3:5ff—see Trail p. 174), in connection with a switch of theme (NonNarr §8.2). The referents are thematic, hence the use of the proximal demonstrative (§6.1).

The order of the post-verbal constituents conforms to the Principle of Natural Information Flow (§4.4), with the established information (εἰς ἑμαυτὸν καὶ Ἀπολλῶν *to Apollos and myself*) preceding δι’ ὑμᾶς (*for your benefit*), which is non-established information, as far as the immediate context is concerned, and comes later in the clause than normal (it is ‘emphatic in Greek’—*UBS* p. 80).

4:6b *so that through us you may learn the [meaning of the saying], Nothing beyond what is written* (ἵνα ἐν ἡμῖν μάθητε τὸ Μὴ ὑπὲρ ὃ γέγραπται). The preposed constituent ἐν ἡμῖν (*through us*) is a referential point of departure for what follows. Given that *for your benefit* was prominent in 6a, it probably signals a switch from *you* to *us*.

4:6c *so that not one of you are puffed up in favour of the one against the other* (ἵνα μὴ εἷς ὑπὲρ τοῦ ἑνὸς φυσιοῦσθε κατὰ τοῦ ἑτέρου). This clause is an implied exhortation *that through us you may learn* not to go *beyond what is written* (NonNarr §7.2.1).

Since εἷς (*one*) follows the negative particle μὴ, it is the focus of the proposition, preposed for extra (emphatic) prominence: *so that not one of you...* (DFNTG §4.1 p. 49). The remainder of the proposition addresses the existing situation: the Corinthians have been *puffed up in favour of the one against the other*. In particular, the constituents ὑπὲρ τοῦ ἑνὸς (*in favour of the one*) and κατὰ τοῦ ἑτέρου (*against the other*) have the article, so their referents will be specific and known (e.g. Paul and Apollos—see ICC p. 82).²⁸

4:7a *For who sees anything different in you?* (τίς γάρ σε διακρίνει;). Γάρ (*For*) introduces supportive material (7-13, according to Hoopert pp. 276-81) that strengthens the implied exhortation of 6c ('The γάρ introduces a reason why such conceit is out or place'—ICC p. 82).

As is normal when a focal constituent (in this case, τίς *who*) precedes the verb, any pronominal that is present (in this case, σε *you*) also precedes the verb (DFNTG §4.2 p. 53). The pronoun is therefore NOT emphatic (contra Morris 1985).

4:7b *What do you have that you did not receive?* (τί δὲ ἔχεις ὃ οὐκ ἔλαβες;). Δὲ signals progression in Paul's reasoning, this time within the supportive material that strengthens the exhortation of 6c, as he builds up to the question of 7d (see Godet p. 220).

4:7c *And if indeed you received it* (εἰ δὲ καὶ ἔλαβες). The repetition of the final constituent of 7b (akin to 'tail-head linkage') slows down the argument and thus gives prominence to the following 'rhetorical question about boasting (a theme that has already been addressed in 1:29, 31) (NonNarr §7.7.1). The additive καὶ is confirmatory, hence the translation *indeed*.

4:7d *why do you boast as if it were not a gift?* (τί κανχᾶσαι ὡς μὴ λαβῶν;).

4:8a *Already you are filled!* (ἤδη κεκορεσμένοι ἐστέ). 'The asyndeton is a new evidence of emotion' (Godet p. 221).

As noted in connection with 3:16b, pre-verbal complements in copular clauses receive more prominence than when they follow the verb. In Paul's writings, ἤδη (*already*) always precedes the verb, so it is not certain that it 'is emphatic by its position' (Trail p. 180, citing Alford and others).

4:8b *Already you have become rich!* (ἤδη ἐπλουτήσατε).

4:8c *Quite apart from us you have become kings!* (χωρὶς ἡμῶν ἐβασιλεύσατε). The order of constituents is marked but ambiguous. 'Like the ἤδη in the two first clauses, χωρὶς ἡμῶν is emphatic' (ICC p. 84), but in what sense? 8d-f suggests that the verb ἐβασιλεύσατε is focal, and this is confirmed by the ICC expansion, 'Without us, who taught you all that you know of the Gospel, and who are still labouring to enter the Kingdom, you are as Kings in the Kingdom' (ibid.). It therefore appears that χωρὶς ἡμῶν is a point of departure, establishing a situation that is applicable to what follows ('This phrase also introduces the theme of a contrast between the apostles' hard life and the easy life which the Corinthian Christians expect to enjoy or think that they already have'—UBS p.83).

²⁸ The preposing of ὑπὲρ τοῦ ἑνὸς (*in favour of the one*) is comparable to the preposing of a pronominal when a focal constituent is preposed (DFNTG ibid.).

4:8d-e *And I wish that you had really become kings* (καὶ ὄφελόν γε ἐβασιλεύσατε). Καὶ associates what follows with 8c.

One of the functions of the emphatic particle γε is to affirm the truth of a previous statement (see Mt. 7:20), hence the gloss *really*.

4:8f *so that we also might be kings with you!* (ἵνα καὶ ἡμεῖς ὑμῖν συμβασιλεύσωμεν). Most commentators consider that the additive καὶ adds *we* to *you* (8c-e).

The order of constituents is marked but ambiguous. The pre-verbal subject ἡμεῖς (*we*) probably signals a switch of topic from *you* to *we* as the new centre of attention (hence the assertion that *we* is ‘emphatic’—*UBS* p. 83). In the comment about the topic, though, I don’t think *you* can be ‘emphatic’ (ibid.). Rather, the order of constituents conforms to the Principle of Natural Information Flow, with the verb focal and prominent: *that we also might be kings with you* (συμβασιλεύσωμεν).

4:9a *For I think* (δοκῶ γάρ). Γάρ (*For*) introduces supportive material (9-13, according to Hoopert pp. 278-81) that strengthens the assertion of 8d-f (‘he ... sets forth ... the *evidence* that he and the other apostles have not yet begun to reign’—Fee p. 174).

4:9b *God has exhibited us apostles last* (ὁ θεὸς ἡμᾶς τοὺς ἀποστόλους ἐσχάτους ἀπέδειξεν). The pre-verbal subject signals a switch of topic from that of 8f.

The pre-verbal constituent ἡμᾶς τοὺς ἀποστόλους (*us apostles*) is also topical.

The DFE ἐσχάτους (*last*) is preposed for extra prominence, either to emphasise its unexpectedness or to contrast with the presumed status of the Corinthians.

4:9c *as though sentenced to death* (ὡς ἐπιθανατίους). This appositional clause is ‘explanatory of the attribute, *the last*’ (Godet p. 224).

4:9d *because we have become a spectacle to the world and to angels and to mortals* (ὅτι θέατρον ἐγενήθημεν τῷ κόσμῳ καὶ ἀγγέλοις καὶ ἀνθρώποις). The material introduced with ὅτι interprets 9b-c by giving a reason or evidence for it.

The DFE θέατρον (*spectacle*) is preposed for (emphatic) prominence.

4:10a *We are fools for the sake of Christ* (ἡμεῖς μωροὶ διὰ Χριστόν). The absence of a connective is consistent with 10-13 being an amplification of 9 (Hodge p. 73). (Also in 11.)

The subject pronoun ἡμεῖς (*we*) that begins this proposition is a referential point of departure by renewal, as Paul starts to contrast *we* and *you*.

4:10b *but you are wise in Christ* (ὑμεῖς δὲ φρόνιμοι ἐν Χριστῷ). In 10b-f, the subject pronoun begins the proposition to signal the change of topic.

In 10b, 10d and 10f, δὲ signals progression within the pair of propositions from the first to the second.

4:10c-d *We are weak, but you are strong* (ἡμεῖς ἀσθενεῖς, ὑμεῖς δὲ ἰσχυροί).

4:10e-f *You are held in honour, but we in disrepute* (ὑμεῖς ἔνδοξοι, ἡμεῖς δὲ ἄτιμοι). ‘In this last contrast the apostle reverses the order of the two terms... This is by way of transition to one or two traits of detail in the apostolic life which he is about to draw. Indeed, the word ἄτιμοι, *despised*, is the theme of the following verses’ (Godet p. 226).

4:11a-b *To the present hour we are hungry and thirsty* (ἄχρι τῆς ἄρτι ὥρας καὶ πεινώμεν καὶ διψῶμεν). This verse begins with a temporal construction (ἄχρι τῆς ἄρτι ὥρας *to the present hour*) that marks a switch of situation from the general time of 9-10 (encompassing past and present) to a specific end point (*the present hour*) of this continuous span of time (*DFNTG* §2.2).

4:11c-e *we are poorly clothed and beaten and homeless* (καὶ γυμνιτεύομεν καὶ κολαφιζόμεθα καὶ ἀστατοῦμεν).

4:12a *and we grow weary* (καὶ κοπιῶμεν).

4:12b *working with our own hands* (ἐργαζόμενοι ταῖς ἰδίαις χερσίν). A **post**-nuclear participial clause, describing the manner by which *we grow weary* (Hoopert p. 280). It is NOT backgrounded with respect to 12a.

4:12c-d *When reviled, we bless* (λοιδορούμενοι εὐλογοῦμεν). Λοιδορούμενοι (*When reviled*) is a pre-nuclear participle in Greek, so is backgrounded with respect to *we bless*.

4:12e-f *when persecuted, we endure* (διωκόμενοι ἀνεχόμεθα). Διωκόμενοι (*When persecuted*) is also a pre-nuclear participle, so is backgrounded with respect to *we endure*.

4:13a-b *when slandered, we speak kindly* (δυσφημούμενοι παρακαλοῦμεν). Again, δυσφημούμενοι (*When slandered*) is a pre-nuclear participle, so is backgrounded with respect to *we speak kindly*.

4:13c *We have become like the rubbish of the world* (ὡς περικοθήματα τοῦ κόσμου ἐγενήθημεν). The focal constituent ὡς περικοθήματα τοῦ κόσμου *like the rubbish of the world* is preposed for extra (emphatic) prominence (NonNarr §5.2.1).

4:13d *the dregs of all things, until now* (πάντων περίψημα ἕως ἄρτι). The genitive πάντων (*of all things*) is preposed within this phrase to give it extra (emphatic) prominence (NonNarr §5.5).

ἕως ἄρτι (*until now*) forms an *inclusio* with ἄχρι τῆς ἄρτι ὥρας (*to the present hour—11a*). Meyer says that Paul ‘repeats with emphatic force at the close of the description the selfsame thought with which it had began [*sic.*] in ver. 11’ (p. 101). However, this doesn’t mean that 13d itself contains a device for emphasising ἕως ἄρτι.

(4:14-21: Fatherly Admonition)

There is good supporting evidence for the beginning of a new sub-unit at 4:14, which includes the absence of a connective (asyndeton— NonNarr §8.3), the summary pronoun ταῦτα (*these things—§8.4*), the end of an *inclusio* at 4:13 (§8.5) and a shift of person from 1st plural to singular (§8.11).

4:14a *I am not writing these things to make you ashamed* (Οὐκ ἐντρέπων ὑμᾶς γράφω ταῦτα). The preposed focal constituent is a participial clause: ἐντρέπων ὑμᾶς (*shaming you*). It is preposed to give it extra prominence (as a foil, to set off 14b to advantage by contrast—NonNarr §5.2.1).

The referents of the proximal demonstrative ταῦτα (*these things*) are ‘the harsh, sarcastic words he used earlier in this chapter, especially in 4:6-13’ (*TrNotes*) and are thematic (§6.1).

4:14b *but to admonish you as my beloved children* (ἀλλ’ ὡς τέκνα μου ἀγαπητὰ νουθετῶ[ν]). See 2:12b on ἀλλὰ (*but*) linking negative and positive propositions.

The DFE ὡς τέκνα μου ἀγαπητὰ (*as my beloved children*) is preposed to give it extra (contrastive) prominence.

4:15a *For if you have ten thousand guardians in Christ* (ἐὰν γὰρ μυρίους παιδαγωγούς ἔχητε ἐν Χριστῷ). Γὰρ (*For*) introduces supportive material (the whole of 15) that strengthens 14 (‘The reason for his taking on himself this duty—*ICC* p. 89).

This pre-nuclear subordinate clause signals a switch to a hypothetical situation that provides the point of departure for the contrasting proposition in 15b.

The constituent μυρίους παιδαγωγούς (*ten thousand guardians*) is preposed as a foil, to set off *many fathers* to advantage by contrast (NonNarr §5.2.1).

4:15b *yet you do not have many fathers* (ἀλλ’ οὐ πολλοὺς πατέρας). ἀλλὰ makes explicit the concessive relationship between 15a and 15b, which would otherwise need to have been deduced from the content of the two propositions (NARR §6.2).

4:15c *For in Christ Jesus through the gospel I became a father to you* (ἐν γὰρ Χριστῷ Ἰησοῦ διὰ τοῦ εὐαγγελίου ἐγὼ ὑμᾶς ἐγέννησα). Γὰρ (*For*) again introduces supportive material (the following proposition) that strengthens what precedes (15b).

The order of constituents is marked but ambiguous. ‘It should be remarked that Paul prefixes to the idea of his labour the two qualifications: *in Christ Jesus* and *by the gospel*’ (Godet p. 231). I take this to imply that ἐν Χριστῷ Ἰησοῦ and διὰ τοῦ εὐαγγελίου are preposed to establish points of departure for the rest of the proposition. The order of constituents in the rest of the proposition suggests an identificational structure (NonNarr §2.1). The presupposition is that someone became a father to you; the focus is who that someone was: *I* (ἐγὼ).

4:16 Οὖν (*then*) marks the resumption of the main theme line. 14 was an expository THESIS, indicating that Paul’s purpose in writing was to admonish his readers. This was followed, in 15, by supportive information. When the mainline is resumed with the exhortation (admonishment) of 16, οὖν is used (NonNarr §3.6).

The following is a flow chart for 4:14-16.

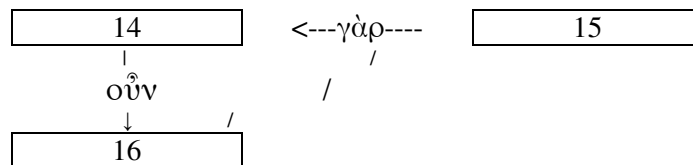

4:16a *I urge you* (παρακαλῶ ὑμᾶς). The orienter μενπαρακαλῶ ὑμᾶς (*I urge you*) gives prominence to 16b (NonNarr §7.7).

4:16b *be imitators of me* (μιμηταί μου γίνεσθε). A direct imperfective (‘present’) imperative—something that the Corinthians are to keep on doing (NonNarr §§7.2.1-2).

4:17a *For this reason I sent you Timothy* (διὰ τοῦτο ἔπεμψα ὑμῖν Τιμόθεον). The referential connective διὰ τοῦτο (*for this reason*) is used anaphorically to relate inferentially to a specific referent which is thematic (NonNarr §6.1). The specific referent is 16 (‘Because I desire you to prove imitators of me, I sent Timothy’—ICC p. 90).

4:17b *who is my beloved and faithful child in the Lord* (ὃς ἐστίν μου τέκνον ἀγαπητὸν καὶ πιστὸν ἐν κυρίῳ). An ‘appositional’ non-restrictive relative clause, used in connection with sequential progression, in which a constituent of the comment of one proposition (here, *Timothy*) becomes the topic of the next (NonNarr §4.1).

The preposing of the ‘unemphatic’ pronominal genitive μου (*my*) within the complement suggests that Paul is still topical. It may also give prominence to the rest of the constituent (DFNTG §4.5 p. 64).

The absence of the article with ἐν κυρίῳ (literally, ‘in Lord’) gives extra prominence to this focal constituent.

4:17c *who will remind you of my ways in Christ Jesus* (ὃς ὑμᾶς ἀναμνήσει τὰς ὁδοὺς μου τὰς ἐν Χριστῷ [Ἰησοῦ]). A further non-restrictive relative clause. This one is continuative, and has the effect of backgrounding 17a-b with respect to 17c (DFNTG §11.2 p. 191).

The pronoun ὑμᾶς has probably been preposed to signal a switch of attention back to *you*, following the comment of 17b about Timothy.

4:17d *as I teach them everywhere in every church* (καθὼς πανταχοῦ ἐν πάσῃ ἐκκλησίᾳ διδάσκω). The DFE πανταχοῦ ἐν πάσῃ ἐκκλησίᾳ (*everywhere in every church*) is preposed to give it extra (emphatic) prominence.

4:18-21. Δὲ signals progression within Paul's reasoning. He first explains why he has sent Timothy (17), then comments on a specific response to him not coming himself (18), before assuring them that he will be coming soon to deal with those who have responded in that way (19-21).

The following is a flow chart for 4:17-21.

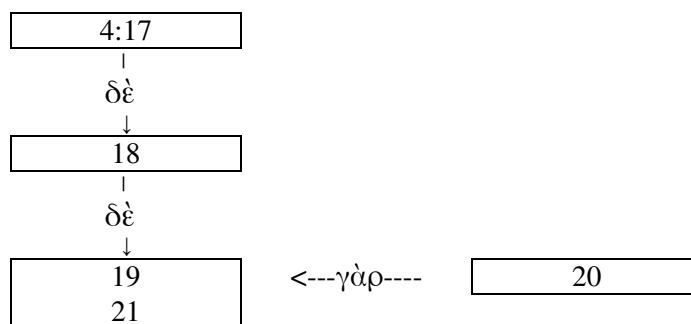

4:18a. *as to my not coming to you* (ὡς μὴ ἐρχομένου μου πρὸς ὑμᾶς). This pre-nuclear subordinate clause signals a switch of situation from that of 17 and provides a point of departure for 18b. (Contrast RSV, which places ‘*as though I were not coming to you*’ after 18b, so that it becomes focal.)

4:18b *some have become arrogant* (ἐφρυσιώθησάν τινες). The subject follows the verb because attention does not switch to *some*. Rather, attention is going to be on what *I* will do when *I come to you* (18-21) (NonNarr §4.3.2).

4:19a *But I will come to you soon* (ἐλεύσομαι δὲ ταχέως πρὸς ὑμᾶς). Δὲ signals further progression within Paul's reasoning (see below on 19c).

Although *I will come* (ἐλεύσομαι) contrasts with *my not coming to you* (18a), Paul has not given focal prominence to either the verb or the adverb ταχέως (*soon*—contra *UBS*). If any part of 19 is more prominent than the rest, it is the post-nuclear conditional clause ἐὰν ὁ κύριος θελήσῃ (*if the Lord wills*—19b) or 19c-d (see below).

4:19b *if the Lord wills* (ἐὰν ὁ κύριος θελήσῃ). This conditional clause is NOT pre-nuclear. The change of situation with respect to 18 is from *not coming* to *coming*, not to *if the Lord wills* (DFNTG §2.2).

The order of constituents is marked but ambiguous (DFNTG §3.8.1). Since *the Lord* is established information (see 17b), the verb is focal.

4:19c *and I will find out not the talk of these arrogant people* (καὶ γνώσομαι οὐ τὸν λόγον τῶν πεφρυσιωμένων). Καὶ associates 19a-b and 19c-d together, since the progression in Paul's thinking is from those who have become arrogant (18b) to his coming soon to deal with such people (19b+c).

4:19d *but their power* (ἀλλὰ τὴν δύναμιν). See 2:12b on ἀλλὰ (*but*) linking negative and positive propositions. (Also in 20b.)

4:20 *For the kingdom of God depends not on talk but on power* (οὐ γὰρ ἐν λόγῳ ἢ βασιλεία τοῦ θεοῦ ἀλλ' ἐν δυνάμει). Γὰρ (*For*) introduces supportive material (20) that strengthens 19c-d.

The focal constituent ἐν λόγῳ (*on talk*) is preposed, following the negative particle οὐ, to give it extra prominence (as a foil, to set off ἐν δυνάμει (*on power*) to advantage by contrast—NonNarr §5.2.1). The absence of the article with λόγῳ and δυνάμει adds to the focal prominence.

4:21a *What would you prefer?* (τί θέλετε;). Hoopert (pp. 284f) perceives a grounds-HEAD relation between 19 and 21. The absence of a connective (asyndeton) is explained by ‘[t]he emotion caused by this challenge, so boldly thrown out’ (Godet p. 237).

The introduction of a question that is then answered highlights the answer (NonNarr §7.7.4)—in this case, 21b-c.

4:21b-c *Am I to come to you with a stick or with love in a spirit of gentleness?* (ἐν ῥάβδῳ ἔλθω πρὸς ὑμᾶς ἢ ἐν ἀγάπῃ πνεύματί τε πραΰτητος;). It is normal in Greek for the first part of a co-ordinative focal constituent to begin a proposition and be separated from the second part by the verb or another constituent (*DFNTG* §4.4.1 pp. 57f). As in 4:3b, the two parts are linked with ἢ *or*.

4:21c *or with love and/also in a spirit of gentleness?* (ἢ ἐν ἀγάπῃ πνεύματί τε πραΰτητος;).

References

- Breeze, Mary. 1992. Hortatory discourse in Ephesians. *Journal of Translation and Textlinguistics* 5,4.313-47.
- Callow, Kathleen. 1992. The disappearing δέ in 1 Corinthians. In *Linguistics and New Testament Interpretation: Essays on Discourse Analysis*, edited by David Alan Black, Katharine Barnwell and Stephen Levinsohn, 183-93. Nashville: Broadman.
- Conzelmann, Hans. 1975. *1 Corinthians*. Hermeneia—A Critical and Historical Commentary on the Bible, translated by James W. Leitch. Philadelphia: Fortress Press.
- DFNTG*: Levinsohn, Stephen H. 2000. *Discourse Features of New Testament Greek: A Coursebook on the Information Structure of New Testament Greek*. Second edition. Dallas: SIL International.
- Edwards, Thomas Charles. 1979 (original: 1885). *A Commentary on the First Epistle to the Corinthians*. Minneapolis: Klock & Klock.
- Ellingworth, Paul, and Eugene A. Nida. 1976. *A Translator's Handbook on Paul's Letters to the Thessalonians*. New York: United Bible Societies.
- Fee, Gordon D. 1987. *The First Epistle to the Corinthians*. The New International Commentary on the New Testament, edited by F. F. Bruce. Grand Rapids: Zondervan.
- Findlay, G. G. 1980 (original: 1900). *St. Paul's First Epistle to the Corinthians*. Expositor's Greek Testament, vol 2, edited by W. Robertson Nicoll. Grand Rapids: Eerdmans.
- Godet, F.L. 1971 (original: 1886). *The First Epistle to the Corinthians*, translated by A. Cusin. Grand Rapids: Zondervan.
- Grosheide, F. W. 1953. *Commentary on the First Epistle to the Corinthians*. The New International Commentary on the New Testament, edited by F. F. Bruce. Grand Rapids: Eerdmans.
- Heckert, Jakob A. 1996. *Discourse Function of Conjoiners in the Pastoral Epistles*. Dallas: Summer Institute of Linguistics.
- Heimerdinger, Jean-Marc, 1999. *Topic, Focus and Foreground in Ancient Hebrew Narratives*. Journal for the Study of the Old Testament: Supplement Series 295. Sheffield: Sheffield Academic Press.
- Hodge, Charles. 1980 (original: 1857). *An Exposition of the First Epistle to the Corinthians*. Grand Rapids: Baker.
- Hoopert, Daniel Arthur. 1981. *The Discourse Structure of 1 Corinthians 1-4*. M.A. thesis, The University of Texas at Arlington.
- ICC*: Robertson, Archibald, and Alford Plummer. 1971 (original: 1914). *A Critical and Exegetical Commentary on the First Epistle of St. Paul to the Corinthians*. Second edition. The International Critical Commentary, edited by S. R. Driver, A. Plummer and C. A. Briggs. Edinburgh: T. & T. Clark.
- Lenski, R. C. H. 1961. *The Interpretation of St. Paul's First and Second Epistles to the Corinthians*. Minneapolis: Augsburg.
- Meyer, Heinrich August Wilhelm. 1890. *Critical and Exegetical Handbook to the Epistles to the Corinthians*, translated from the fifth edition by D. Douglas Bannerman. Revised and edited by William P. Dickson. New York: Funk & Wagnalls.
- Morris, Leon. 1991. *The First and Second Epistles to the Thessalonians*. Revised edition. Grand Rapids: Eerdmans.
- Terry, Ralph Bruce. 1995. *A Discourse Analysis of First Corinthians*. Dallas: Summer Institute of Linguistics and The University of Texas at Arlington.
- Trail, Ronald. 1995. *An Exegetical Summary of 1 Corinthians 1-9*. Dallas: Summer Institute of Linguistics.
- TrNotes*: Miller, Neva F., and Michael Martens. 1998. *Translator's Notes on 1 Corinthians: Chapters 1 through 7* (preliminary version). Dallas: SIL International.
- UBS*: Ellingworth, Paul, and Howard Hatton. 1985. *A Translator's Handbook on Paul's First Letter to the Corinthians*. London/New York/Stuttgart: United Bible Societies.
- Wallace, Daniel B. 1995. *Greek Grammar Beyond the Basics: An Exegetical Syntax of the New Testament*. Grand Rapids: Zondervan.